

CHAPIN®

100lb STAINLESS STEEL HOPPER
Professional Salt/Halite/Ice Melt Spreader

#82500

NEW!



NEW! One piece solid stainless steel 100lb hopper without any welds, complete with rolled edges



NEW! Large elevated metal grate for better straining and reduces clumping



Enclosed metal gears to withstand the elements



Solid steel linkage opens and closes the gate in incremental steps



Patent pending exclusive salt auger helps agitate product and minimize clumping



Adjustable salt baffle system helps spread salt only where you want it



14" tires provide stability over uneven terrain

Includes grate and rain cover!



800-950-4458 Fax 800-944-4329 www.chapinmfg.com
Chapin International, Inc PO Box 549 Batavia, NY 14021-0549 USA
Due to our ongoing product improvement process, product specifications may change without notice.

CHAPIN®

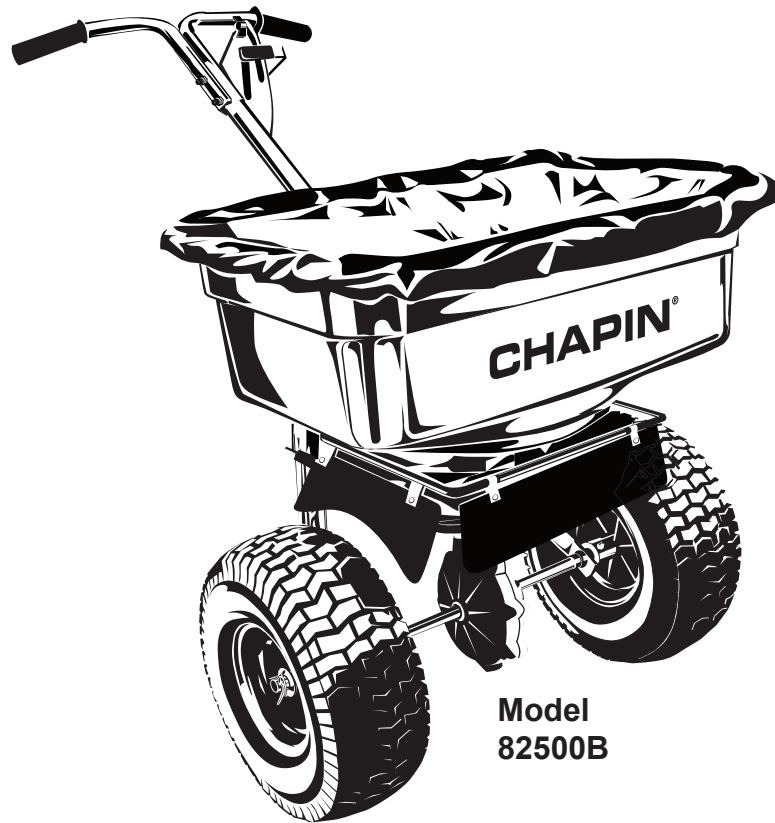

Model
82500B

**FULL BAFFLE SPREADER ASSEMBLY INSTRUCTIONS
ARMADO DEL ESPARCIDOR CON DEFLECTOR COMPLETO
DIRECTIVES D'ASSEMBLAGE DU DÉFLECTEUR COMPLET**

**DO NOT RETURN TO STORE. CALL
CHAPIN CUSTOMER SERVICE:**

NO DEVUELVA A LA TIENDA.

LLAME A SERVICIO A CLIENTES DE CHAPIN:

**NE PAS RETOURNER EN MAGASIN APPELER LE SERVICE À LA
CLIENTÈLE DE CHAPIN :**

800-950-4458

www.chapinmfg.com

014643 R1216

Contents:

Contenido:

Contenu :

Spreader Hardware (Actual size)

Accesorios para esparcidor (tamaño real)

Quincaillerie de l'épandeur (taille réelle)

H-2

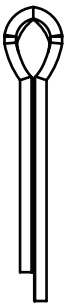

H-3



H-4

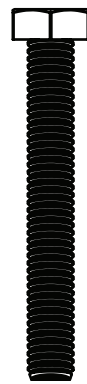

H-5

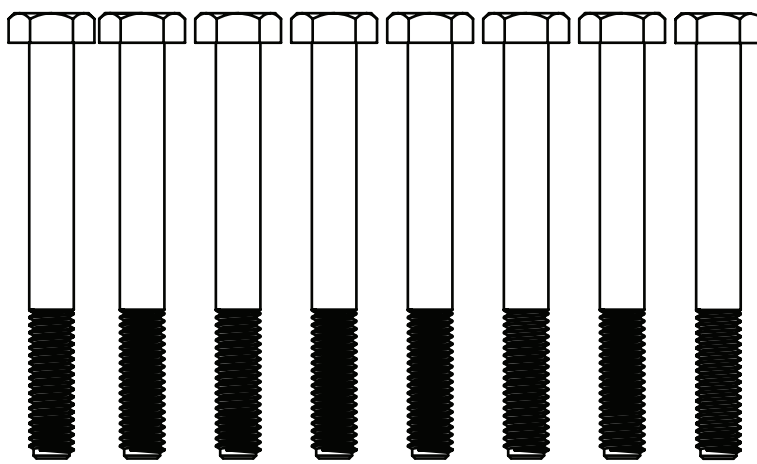

H-6



H-8

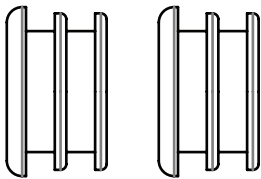

H-7



H-13 (X2)

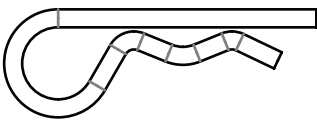

H-11

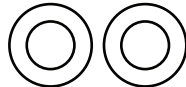

H-12

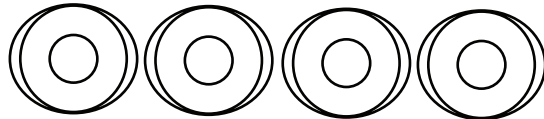

H-9 (X2)

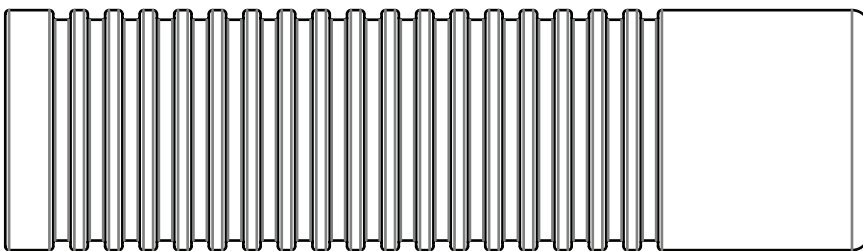

H-10



H-10a

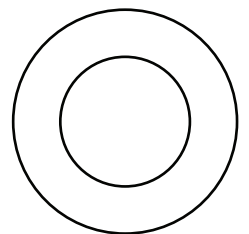

TOOLS NEEDED:

**HERRAMIENTAS
REQUERIDAS:**

OUTILS REQUIS:

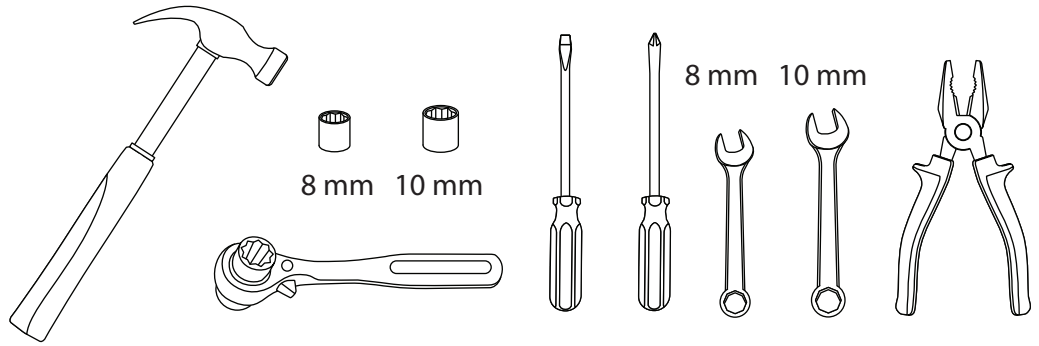

Spreader Components (Not Actual size)

Componentes de la esparcidor (no en tamaño real)

Composants de l'épandeur (taille non réelle)

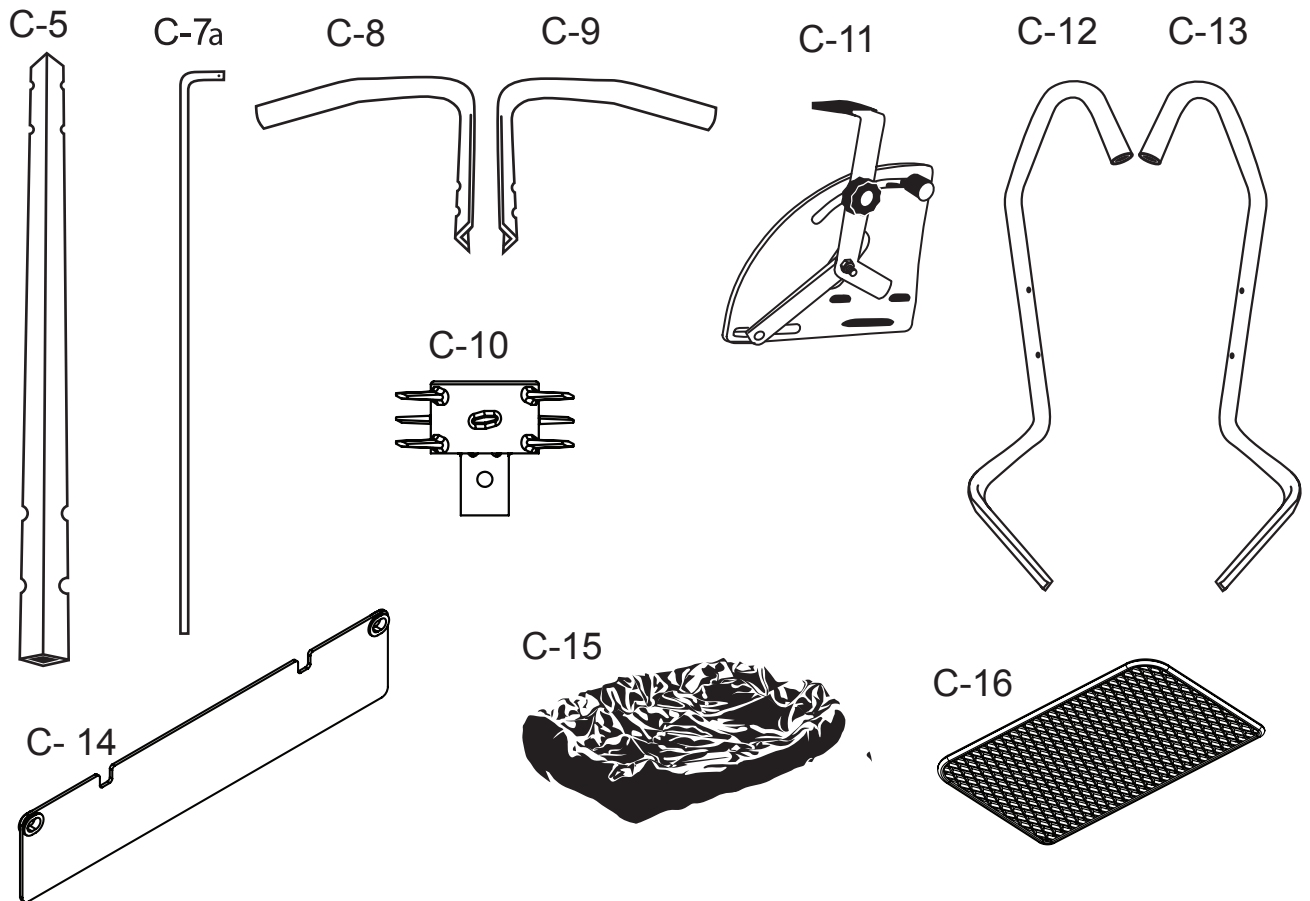

WARNING ⚠️ ADVERTENCIA ⚠️ ADVERTISSEMENT

WARNING: This product contains chemicals, including lead, known to the state of California to cause birth defects and other reproductive harm.
Wash hands after handling.

ADVERTENCIA: Este producto contiene agentes químicos como plomo, que en el Estado de California es conocido por provocar defectos congénitos y otros daños reproductivos. *Lávese las manos después de usarlo.*

AVERTISSEMENT : Ce produit contient des produits chimiques, incluant le plomb, reconnus par l'État de Californie comme causant des anomalies congénitales et autres problèmes reproductifs. *Se laver les mains après toute manipulation.*

1

Handle Bar and Gate Control Assembly (1.1 - 1.10)

Barra de ma'ija y conjunto del control de la compuerta (1.1 - 1.10)

Guide et vanne de d'égagement (1.1 à 1.10)

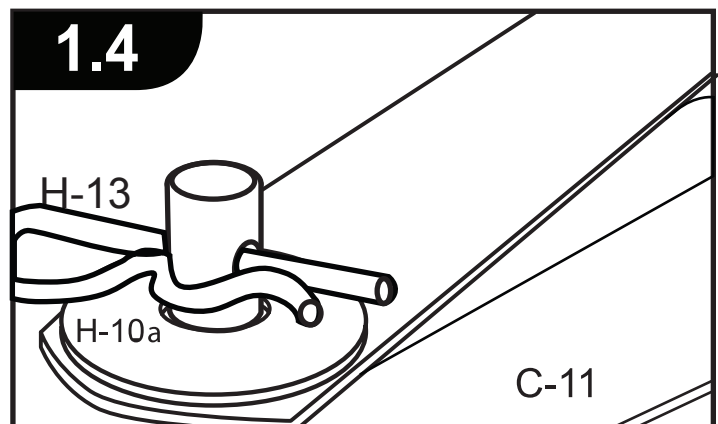
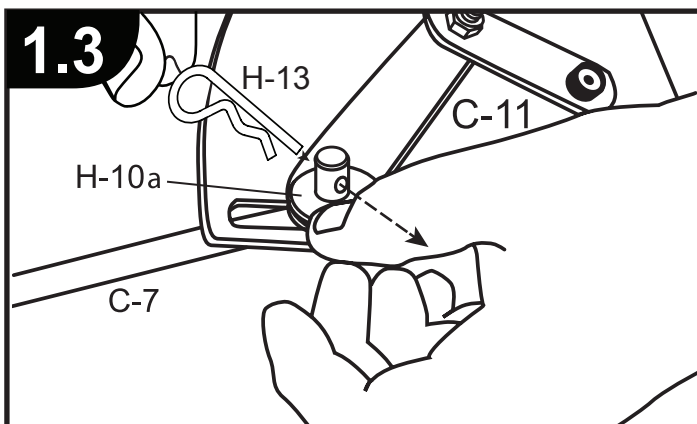
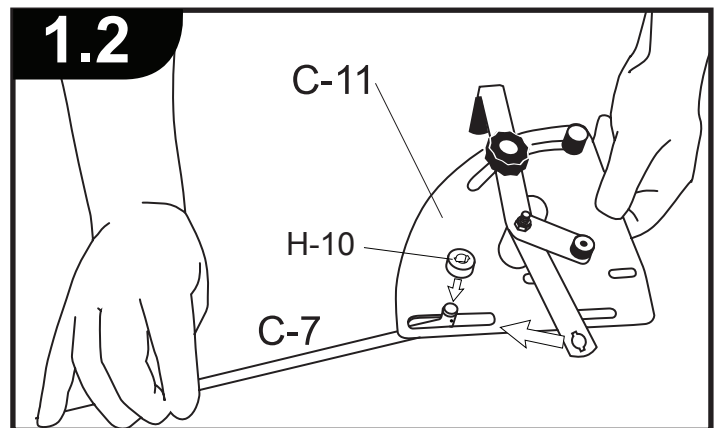
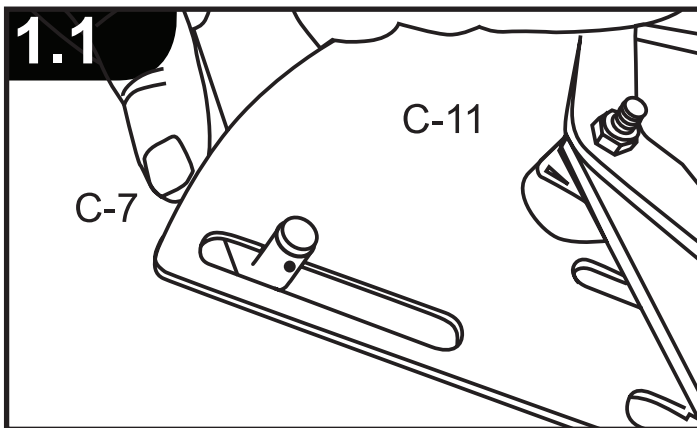
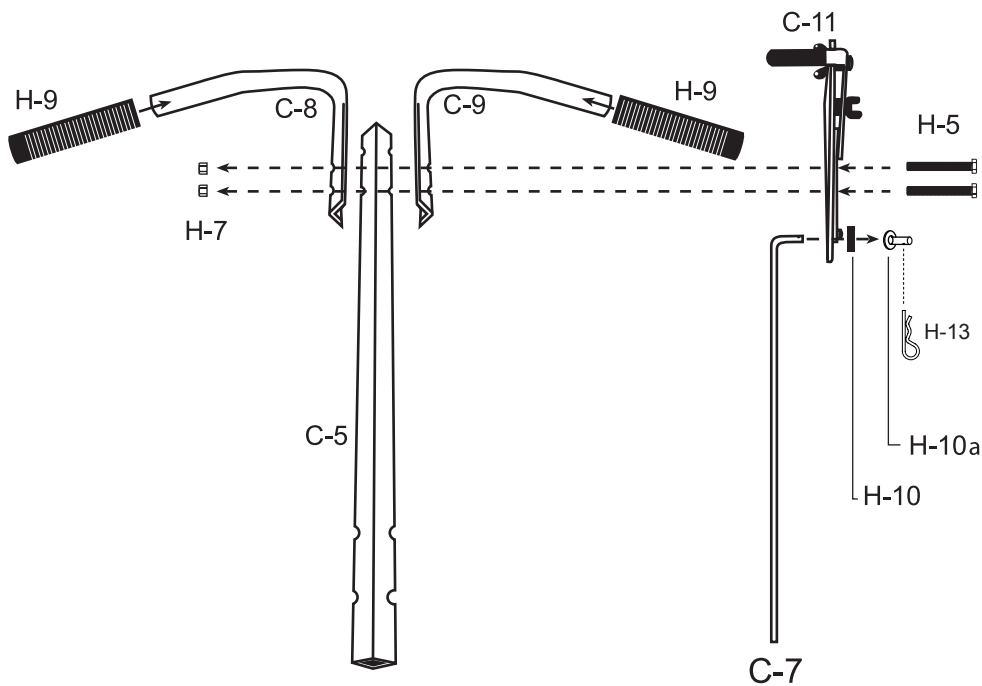

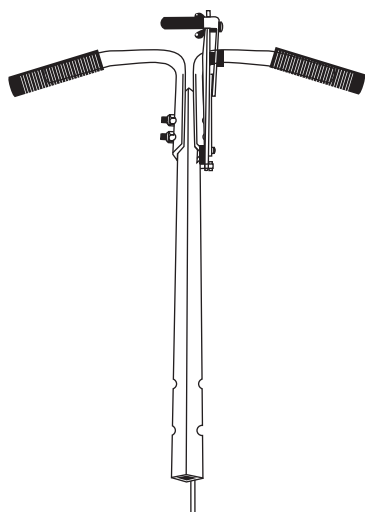
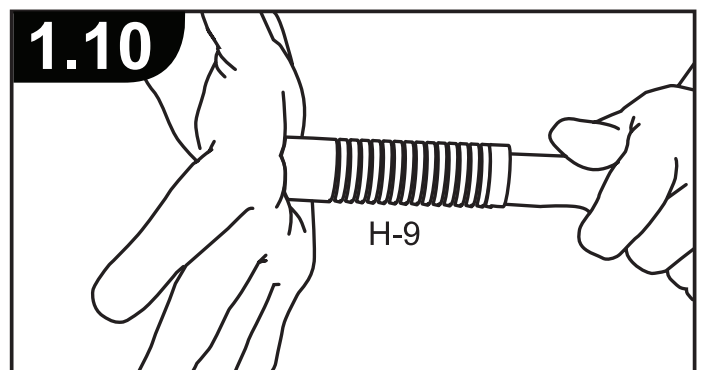
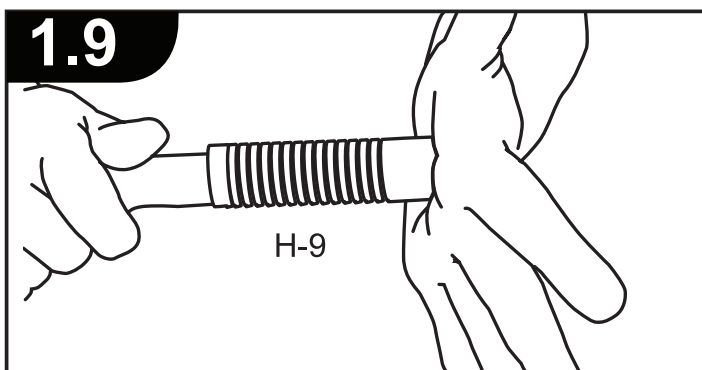
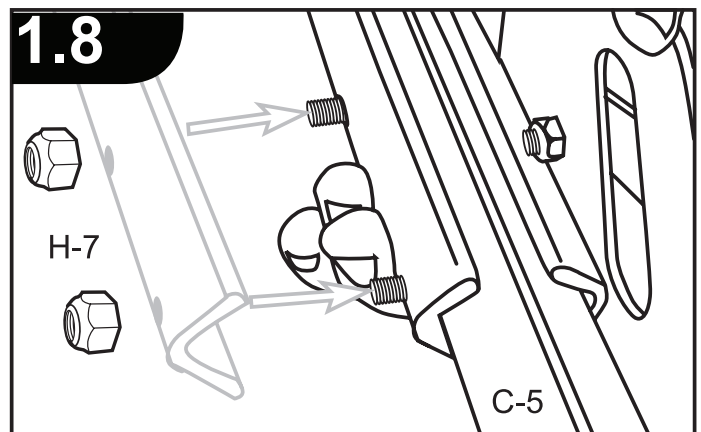
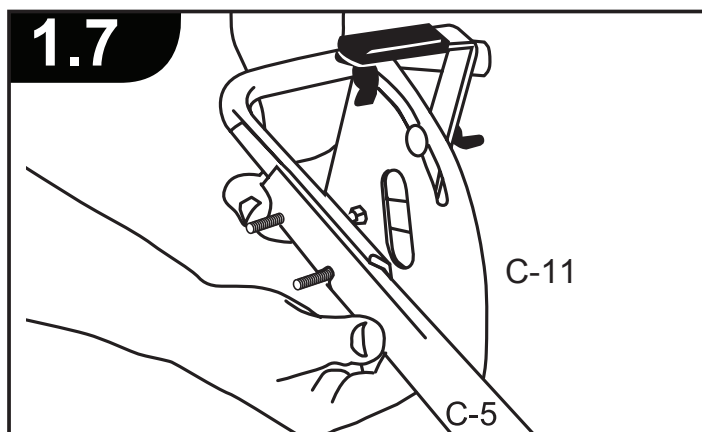
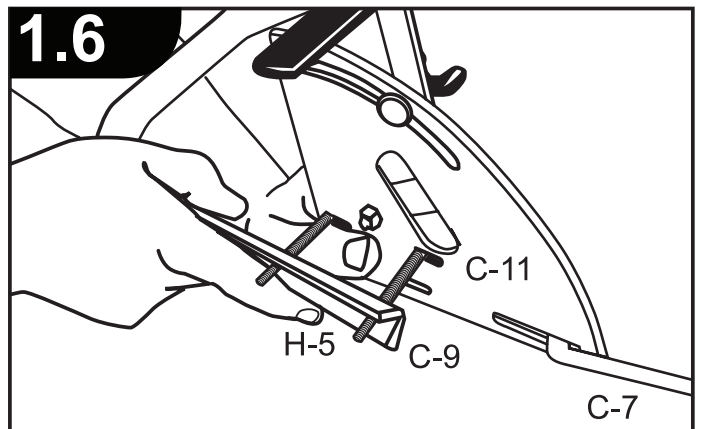
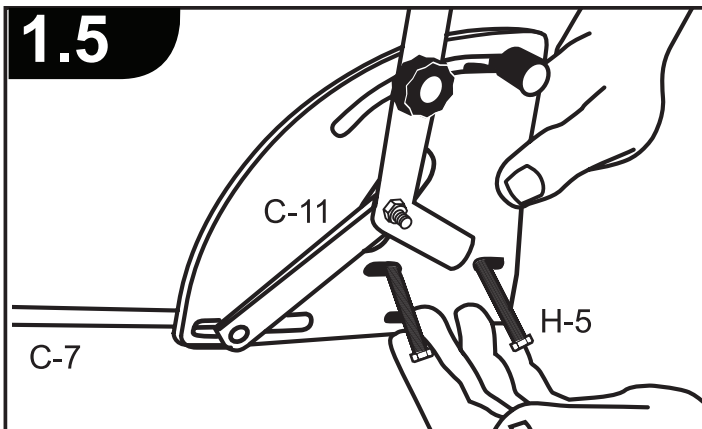

Completed Assembly Ensamblaje completo Assemblage terminé

Note: When installing Gate control assembly (1.8), Tighten both screws enough to hold in place for adjustment of gate control later . (Step 4.7- 4.10)

Nota: Al instalar el conjunto de control de la compuerta (1.8), apriete ambos tornillos lo suficiente para sujetarlo en su sitio para ajustar posteriormente el control de la compuerta. (Paso 4.7 - 4.10)

Remarque : Lors de l'installation de la vanne de dégagement (1.8), serrez suffisamment les deux vis pour maintenir cette dernière en place et pouvoir l'ajuster plus tard. (Étape 4.7 à 4.10)

2

Frame Legs to Hopper assembly (2.1 - 2.2)

Unión de las patas de la estructura al ensamblaje de la tolva (2.1 - 2.2)
Montage des pattes à l'ensemble de la trémie (2.1 - 2.2)

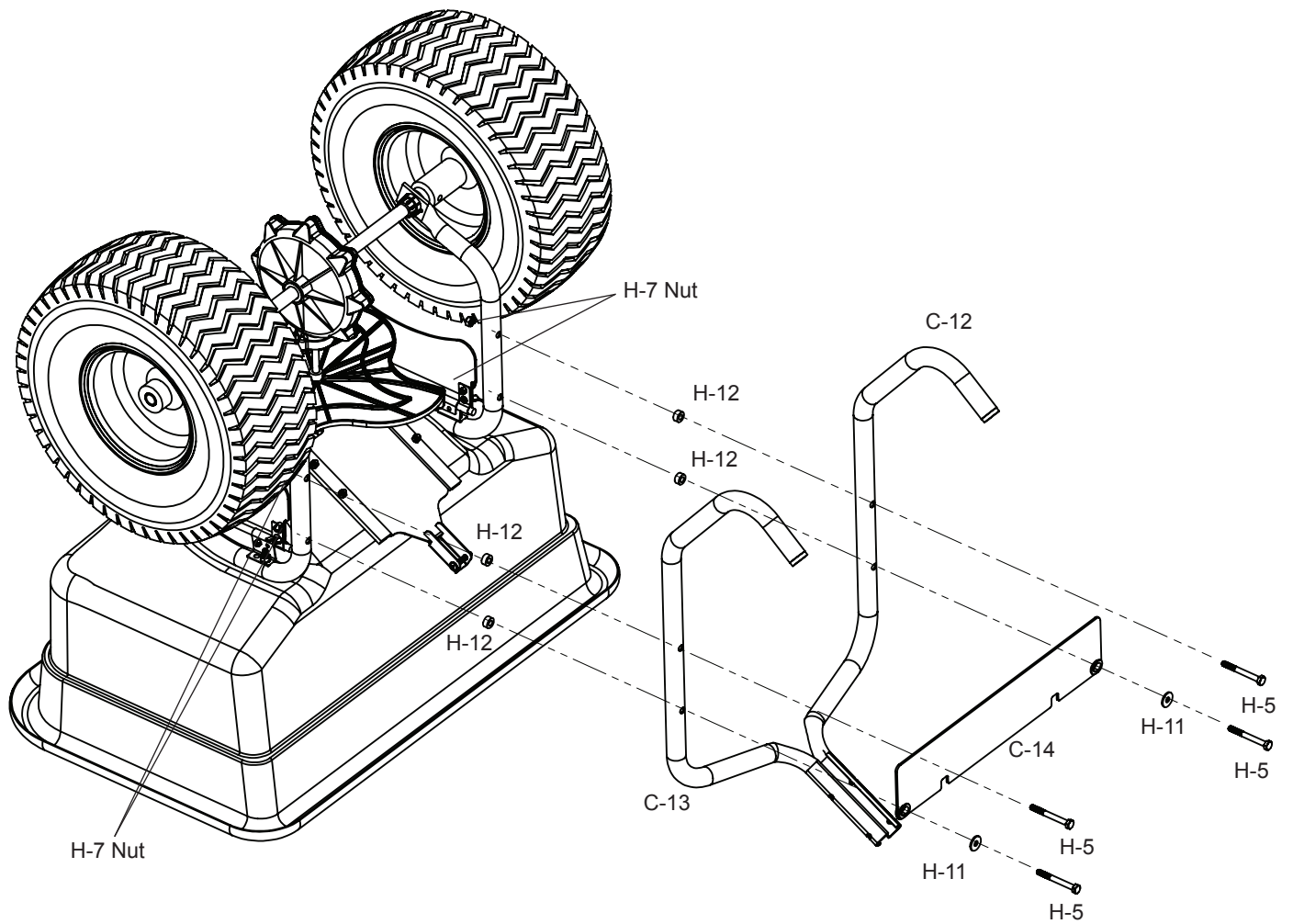

Frame Legs to Hopper assembly (2.1 - 2.2)

Unión de las patas de la estructura al ensamblaje de la tolva (2.1 - 2.2)
Montage des pattes à l'ensemble de la trémie (2.1 - 2.2)

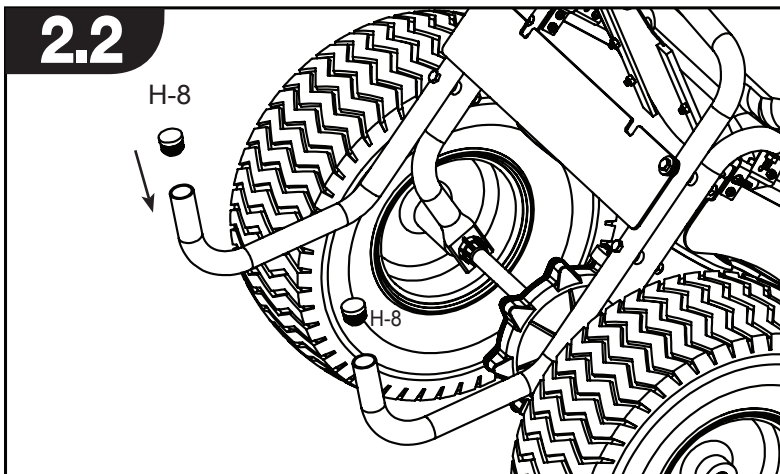
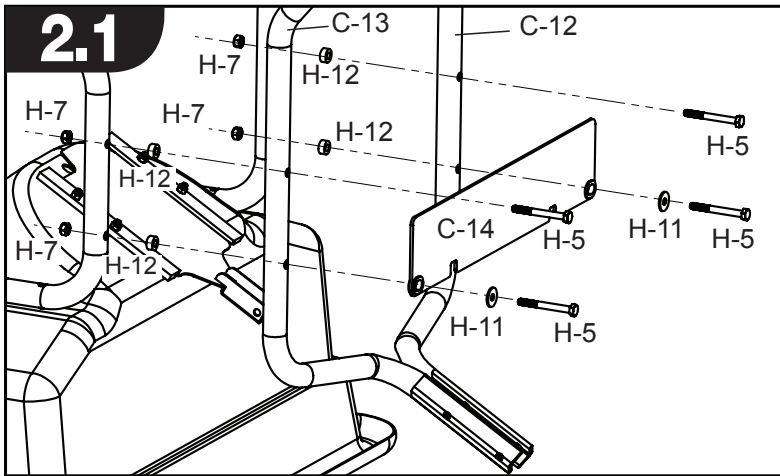

3

Handlebar Assembly to Hopper Frame / Auger Attachment For Salt Spreaders (3.1- 3.11)

Conjunto de la barra de manija al chasis de tolvilla / accesorio de tornillo sin fin para esparcidores de sal (3.1 - 3.11)

Installation du guidon à l'armature de la trémie / Vrille pour épandeurs de sel (de 3.1 à 3.11)

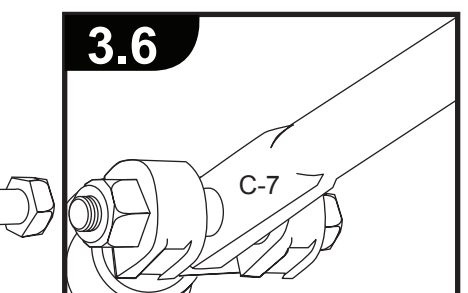
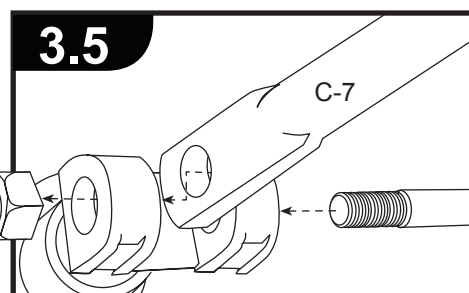
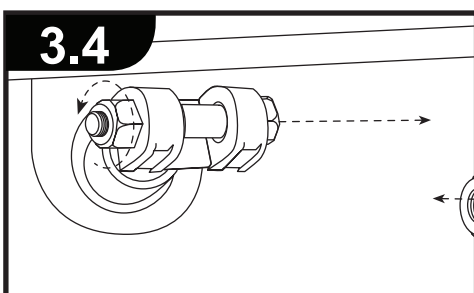
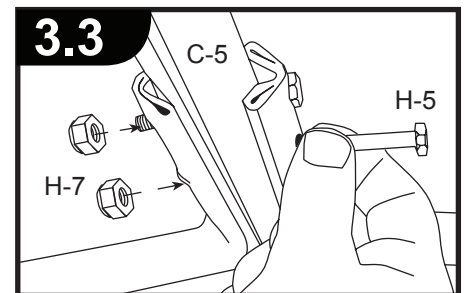
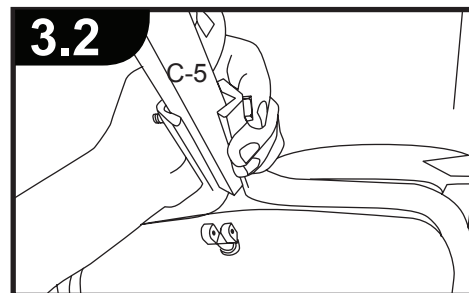
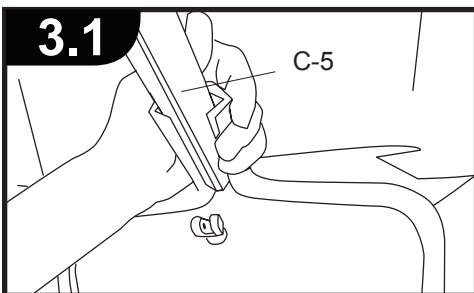
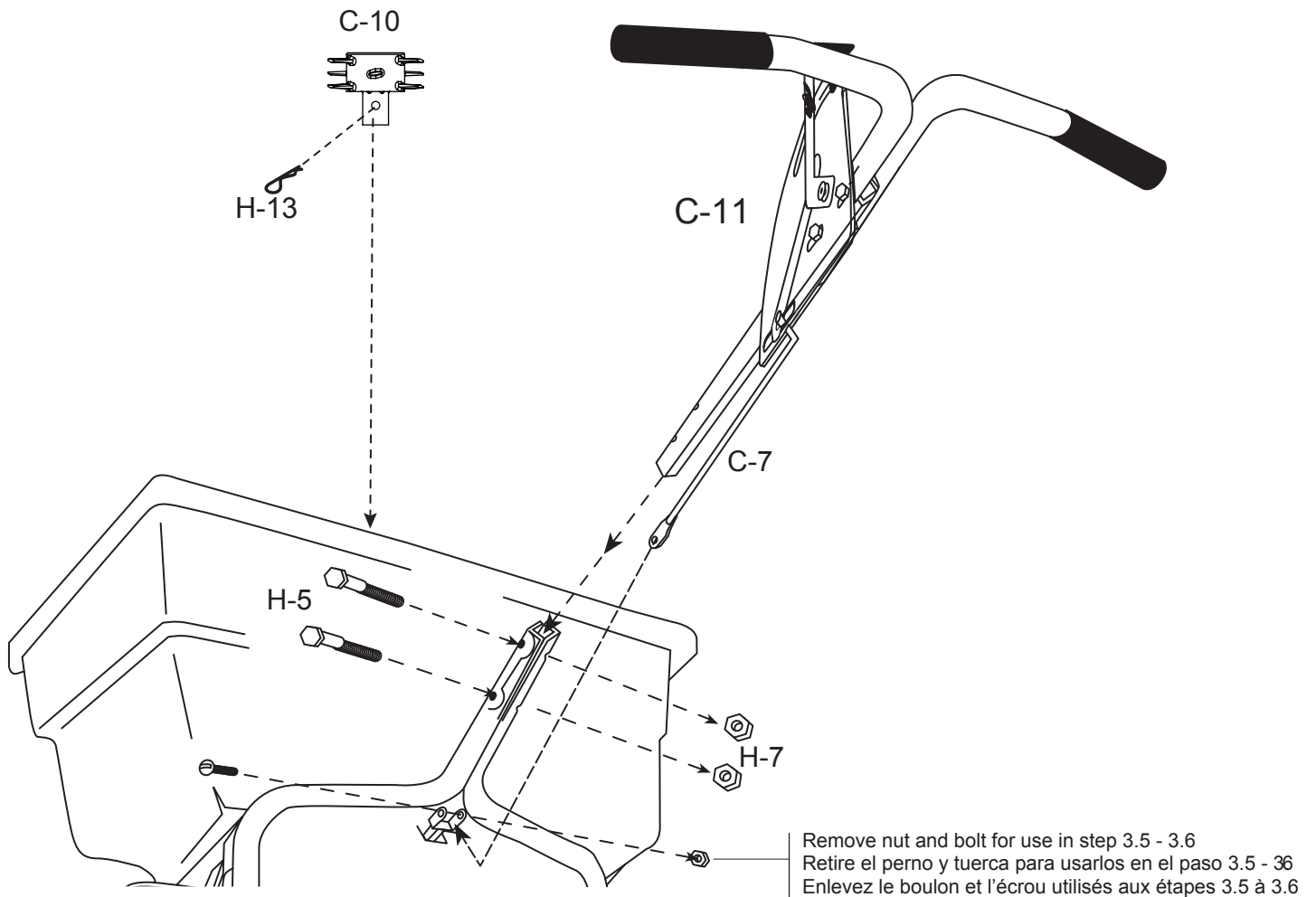

Final Gate Adjustment and Auger Installation (Inside Hopper)

Instalación de ajuste de compuerta y tornillo sin fin (interior de la tolvilla) Ajustement de la vanne et installation de la vrille (à l'intérieur de la trémie)

Note: Complete steps 3.7 - 3.10 only if gate isn't completely closed when lever is in forward position (as shown in 3.7). Once gate is adjusted, tighten both nuts on Gate Control Assembly (C-11).

Nota: Realice los pasos 3.7 - 3.10 solamente si la compuerta no está completamente cerrada cuando la palanca esté en posición hacia adelante (como se muestra en 3.7). Una vez que la compuerta esté ajustada, apriete ambas tuercas en el conjunto de control de la compuerta (C-11).

Remarque : Ne suivez les étapes 3.7 à 3.10 que si la vanne n'est pas entièrement fermée lorsque le levier est en position avant (tel que montré à l'étape 3.7). Une fois la vanne ajustée, serrez les deux écrous sur la vanne de dégagement (C-11).

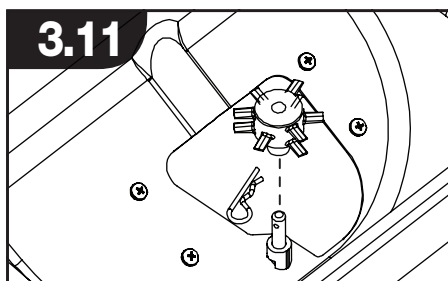
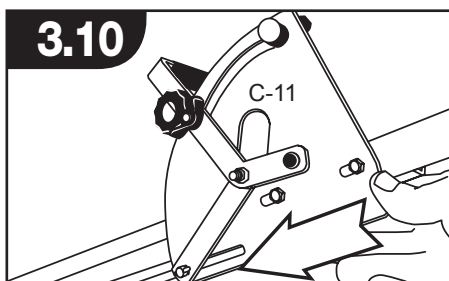
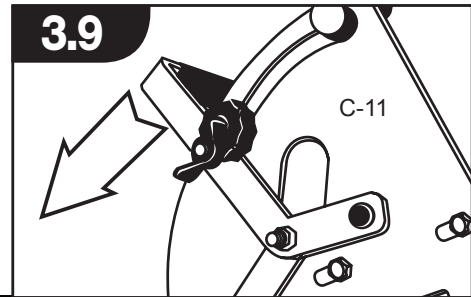
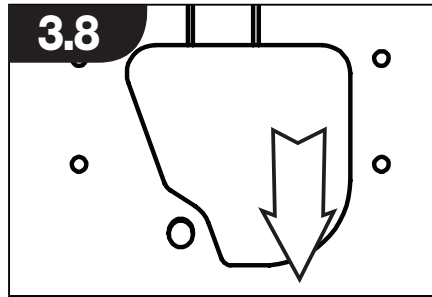
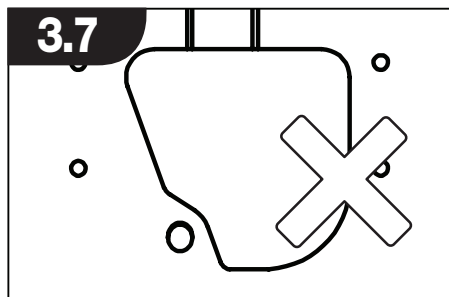

Final Step: After completing gate adjustment, tighten all assemblies before use.

Paso final: Después de completar el ajuste de compuerta, apriete todos los conjuntos antes de usar.

Étape finale : Une fois la vanne ajustée, serrez toutes pièces assemblées avant utilisation.

Completed Assembly
Ensamblaje completo
Assemblage terminé

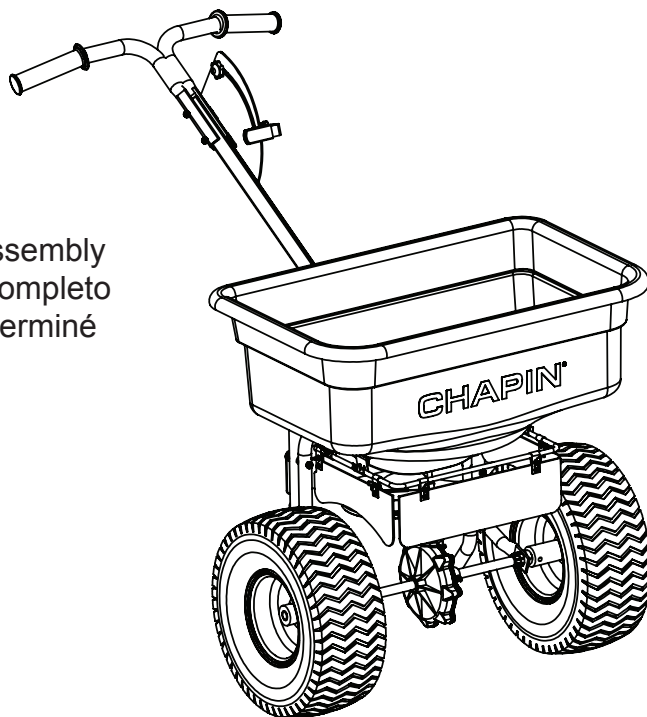

Replacement Parts / Partes de repuesto / Pièces de rechange

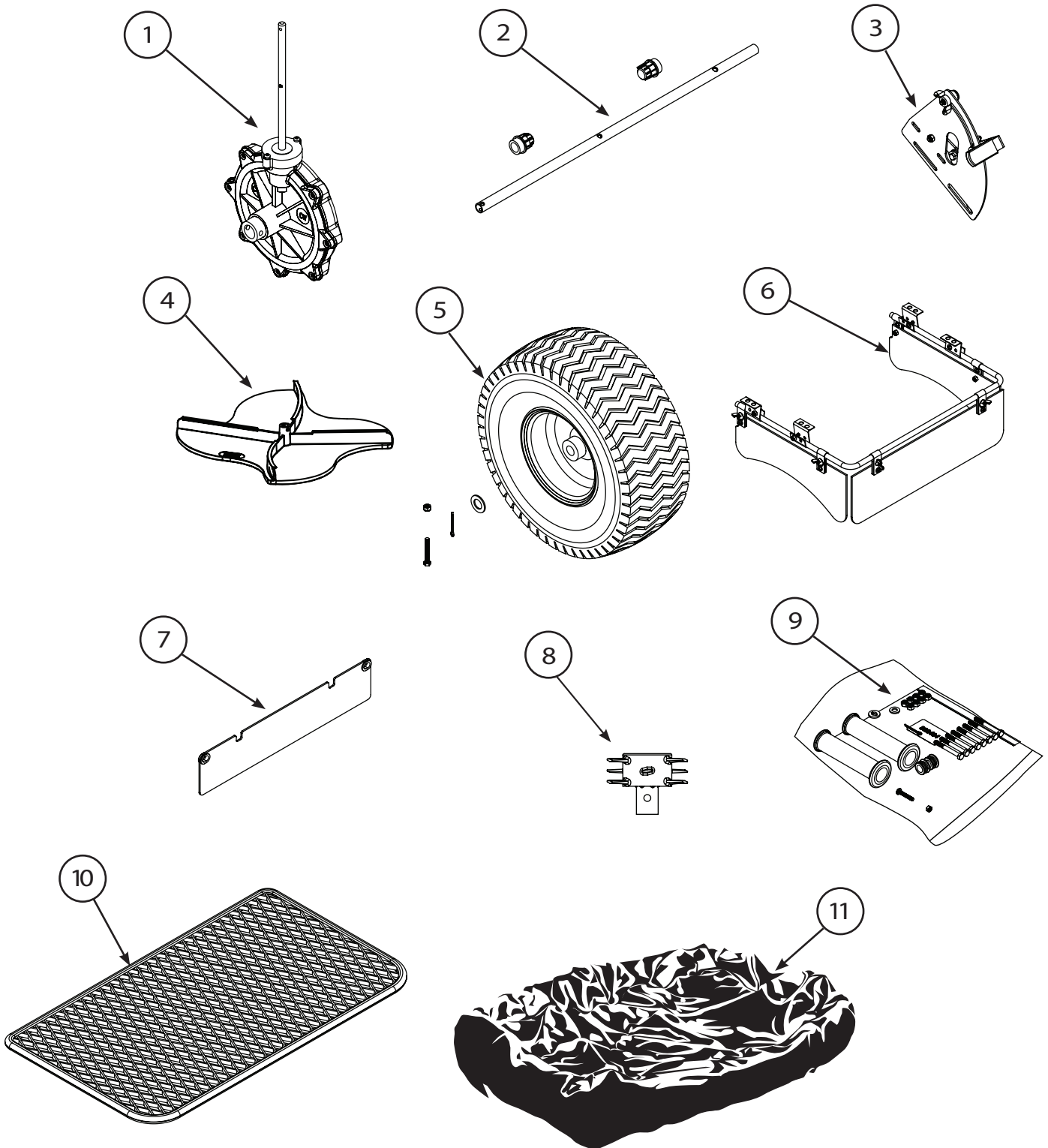

Ref.#	Qty	Part No.	Description / Descripción / Description
1	1	6-9068	Gear Box Assembly / Conjunto de la caja de engranes / Ensemble de la boîte de'engrenages
2	1	6-9009	Drive shaft w/2 bearings / Fletcha de transmisión c/2 conjinetes / Arbre de transmission avec 2 roulements
3	1	6-9038	Gate Control Assembly / Conjunto del control de la compuerta / Ensemble du contrôle de la vanne
4	1	6-9058	Impeller / impulsor / Roue à ailettes
5	1	6-9015	Wheels w/hardware / Ruedas C/herrajes / Roues avec matériel
6	1	6-9025	Salt Baffles / deflectores de la sal / Cloisons de sel
7	1	6-9055	Rear Baffle / Bafle posterior / Cloison arrière
8	1	6-9067	Auger / Taladro / Foreuse
9	1	6-9052	Hardware Bag / Bolsa de herrajes / Sac de matériel
10	1	6-9053	Grate / Parrilla / Grille
11	1	6-9054	Rain Cover / Cubierta para lluvia / Couverture protectrice contre la pluie

CHAPIN CUSTOMER SERVICE: 800-950-4458

CHAPIN INTERNATIONAL, INC. P.O. BOX 549 700 ELLICOTT ST. BATAVIA, NY 14021-0549

APPLICATION CHART

All Season Residential & Professional General Application Guidelines	
Weed Control	1-10
Fertilizer	11-12
Grass Seed - Overseeding	13-14
Grass Seed - New Lawn	16-17
Salt & Ice-Melt	18-20

All Season Residential & Professional Push Spreader Application Conversion Chart																			
Scotts	2	2.5	3	3.25	3.5	4	4.75	5	5.5	6	7	8	9	10	11	12	13	14	15
Chapin	11	11	12	12	12	12	13	13	13	13	14	14	14	14	14	14	15	15	15

TABLA DE APLICACIÓN

Aplicación General Profesional & Residencial para toda temporada Directrices	
Control de hierba	1-10
Fertilizante	11-12
Semilla de pasto - Sobresiembr	13-14
Semilla de pasto - Césped nuevo	16-17
Sal y derretimiento	18-20

Tabla de conversión para la aplicación profesional y residencial del distribuidor de empuje para toda temporada																			
Scotts	2	2.5	3	3.25	3.5	4	4.75	5	5.5	6	7	8	9	10	11	12	13	14	15
Chapin	11	11	12	12	12	12	13	13	13	13	14	14	14	14	14	14	15	15	15

TABLEAU D'APPLICATION

Directives d'application générale résidentielle et professionnelle toute saison	
Désherbage	1-10
Engrais	11-12
Graines de graminées - Sursemis	13-14
Graines de graminées - Nouvelle pelouse	16-17
Sel et produit de déglacage	18-20

Tableau de conversion d'application pour épandeur à pousser résidentiel et professionnel toute saison																			
Scotts	2	2.5	3	3.25	3.5	4	4.75	5	5.5	6	7	8	9	10	11	12	13	14	15
Chapin	11	11	12	12	12	12	13	13	13	13	14	14	14	14	14	14	15	15	15

Sample Spread Pattern

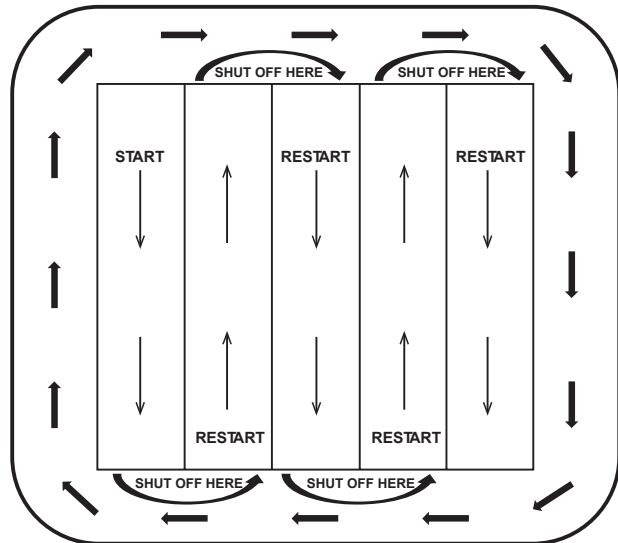

Modèle d'épandage type

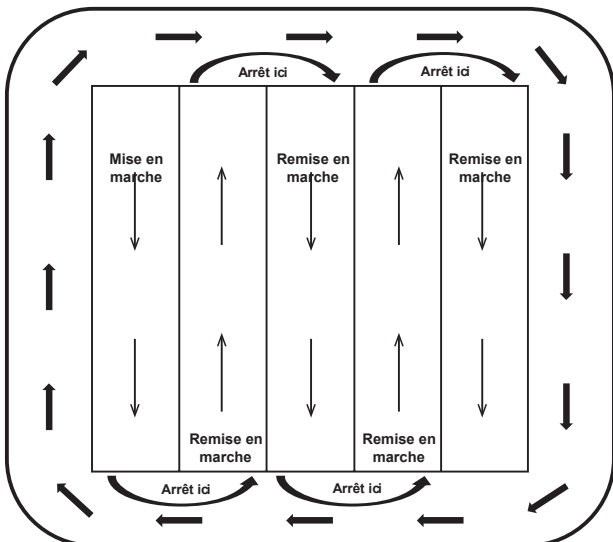

Muestra del patrón de distribución

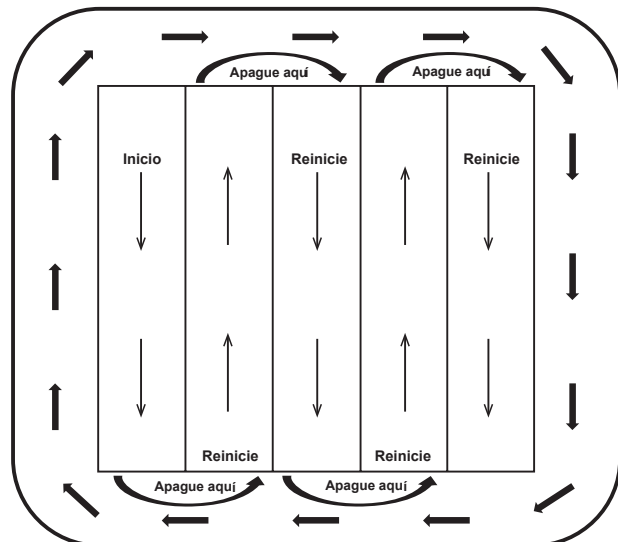

Contents: Contenido: Contenu :

Spreader Hardware (Actual size)
 Accesorios para esparcidor (tamaño real)
 Quincaillerie de l'épandeur (taille réelle)

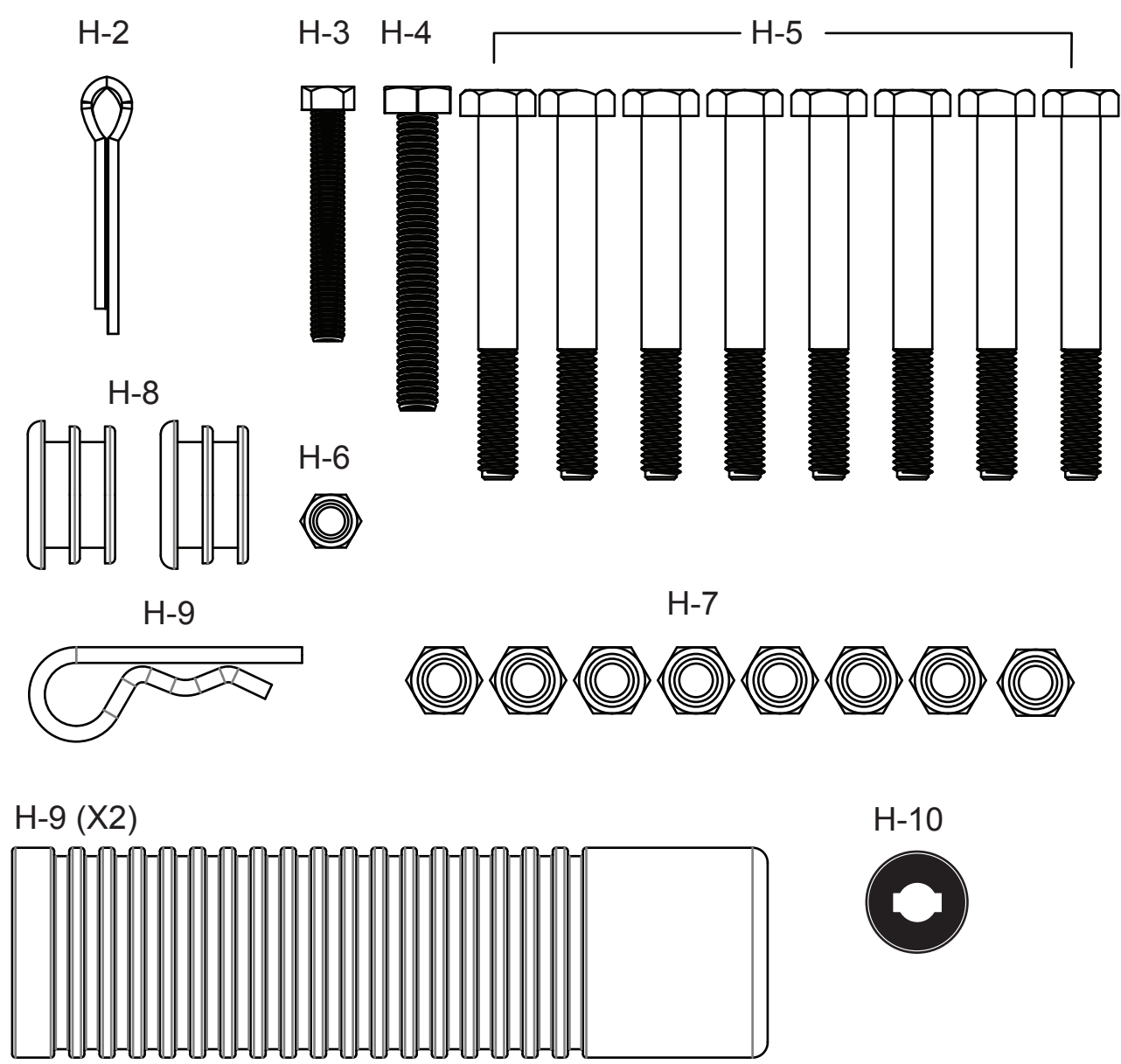

Note: Not all components shown may be needed on your model

Nota: Puede que no todos los componentes mostrados sean necesarios en su modelo.

Remarque: Il se peut que certains des composants montrés ne soient pas requis pour l'assemblage de votre modèle

Spreader Components (Not Actual size)
 Componentes de la esparcidor (no en tamaño real)
 Composants de l'épandeur (taille non réelle)

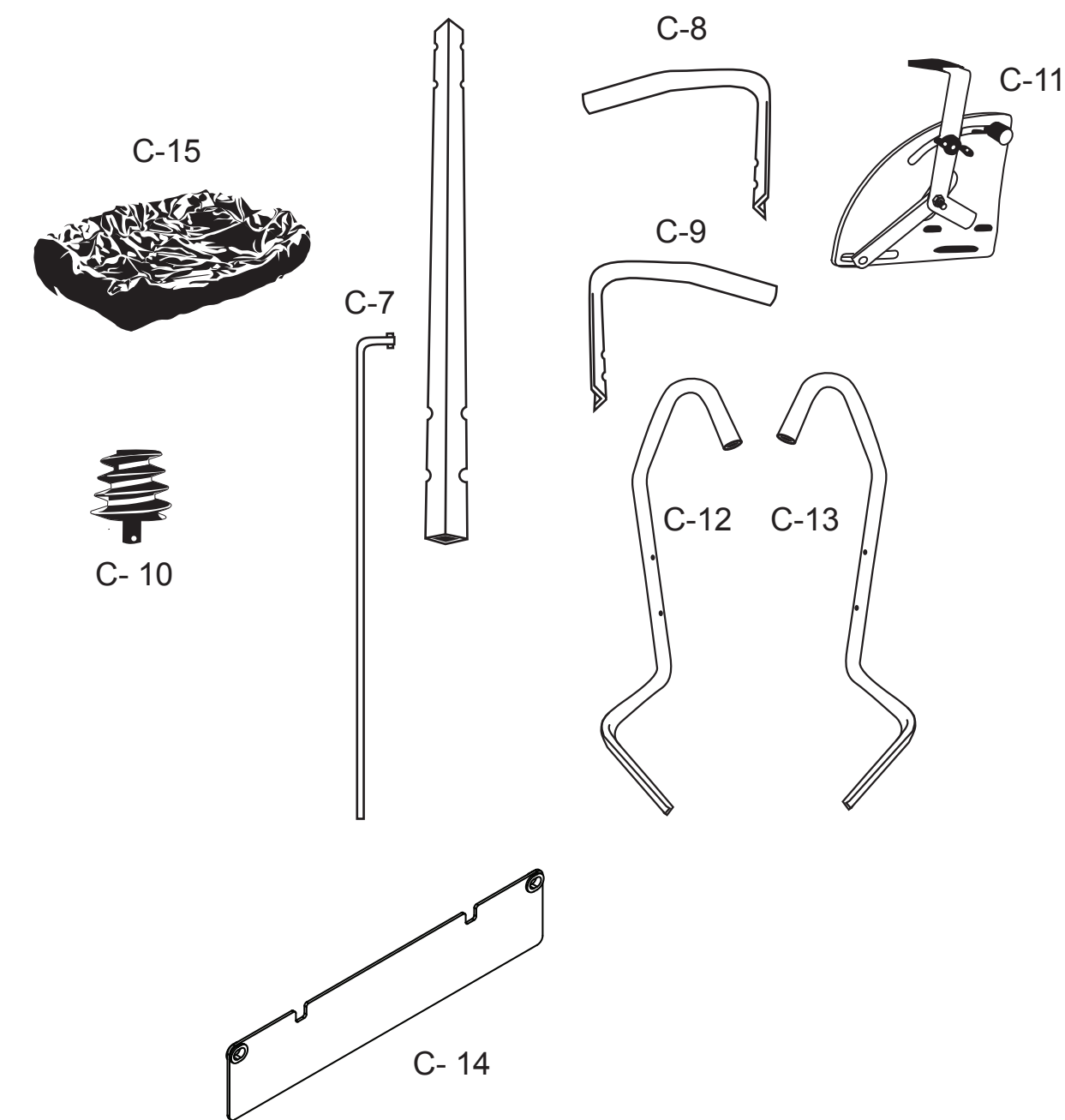

1 Handle Bar and Gate Control Assembly (1.1 - 1.10)

Barra de manija y conjunto del control de la compuerta (1.1 - 1.10)

Guide et vanne de dégagement (1.1 à 1.10)

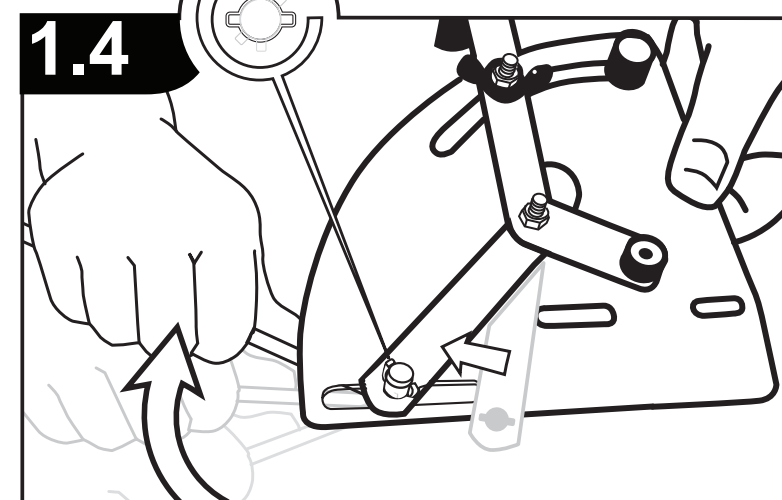
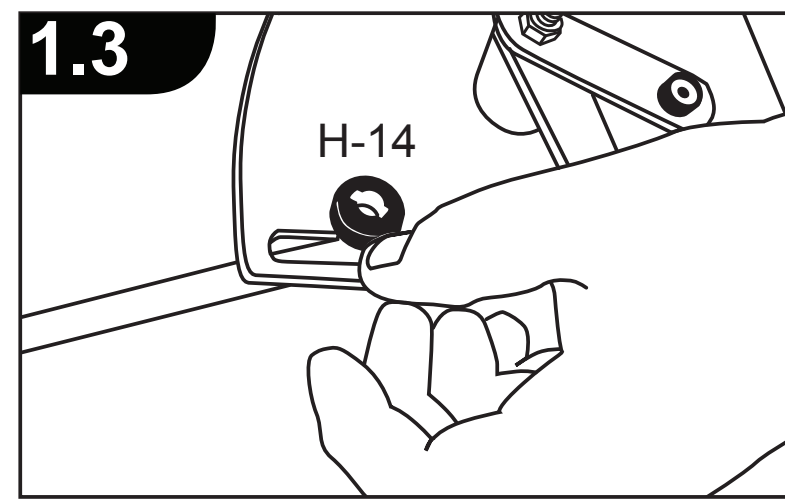
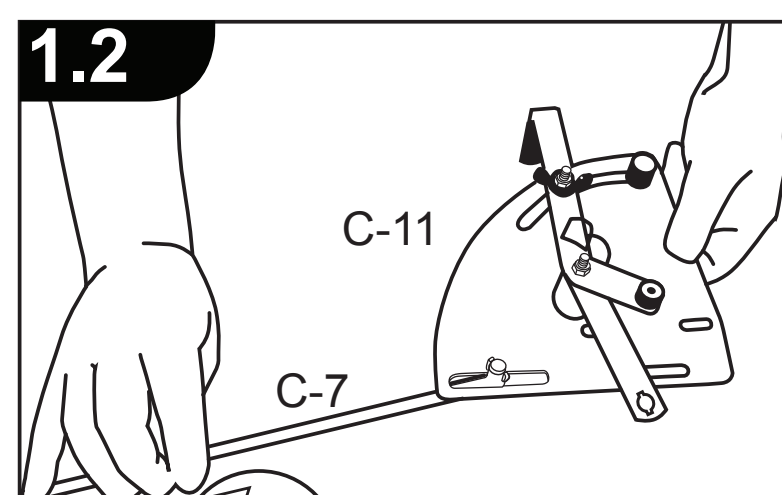
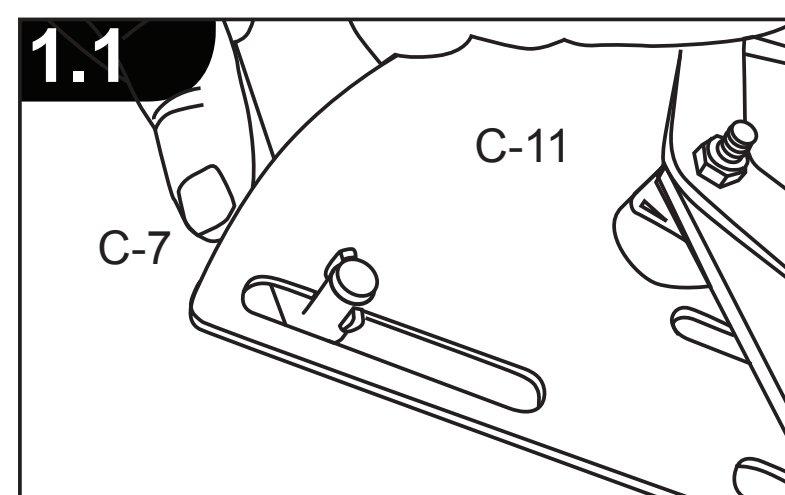
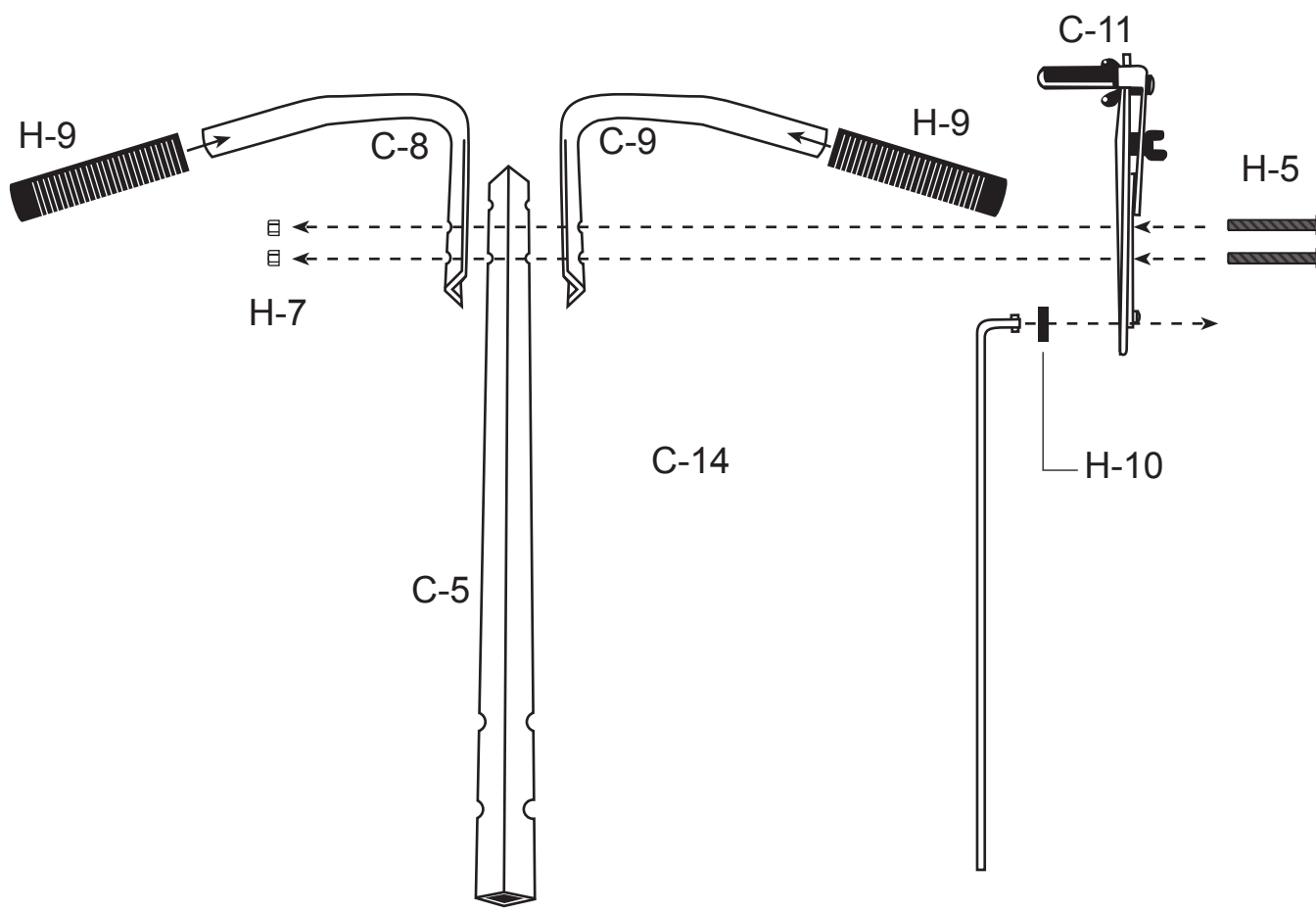

Completed Assembly
 Ensamblaje completo
 Assemblage terminé

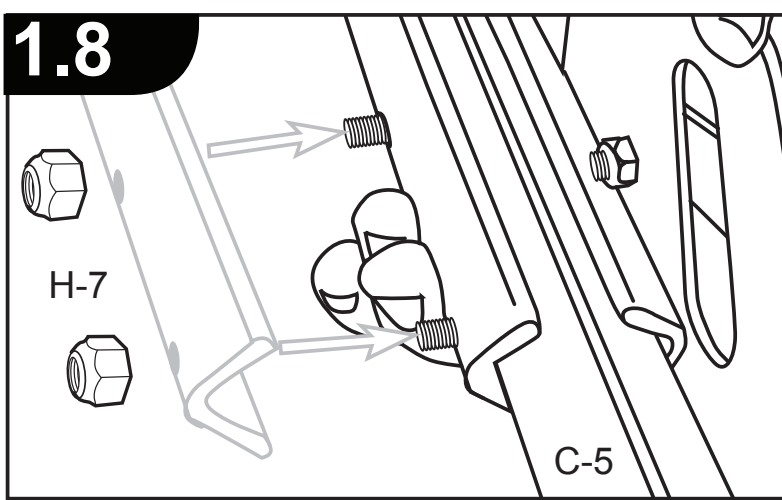
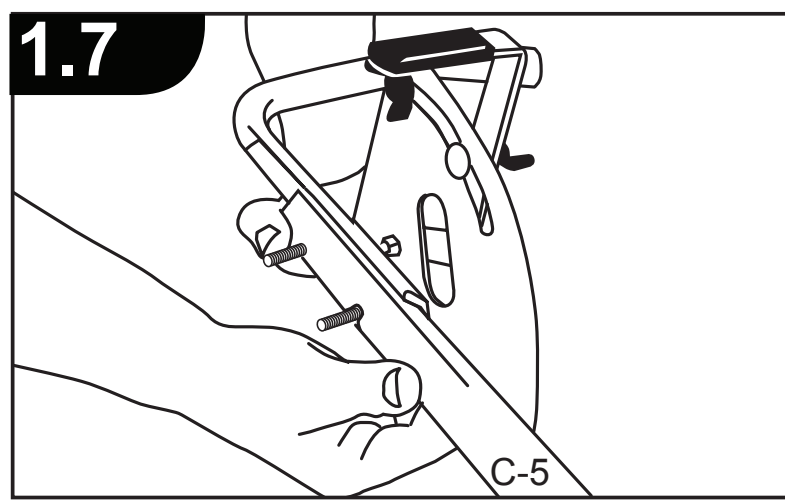
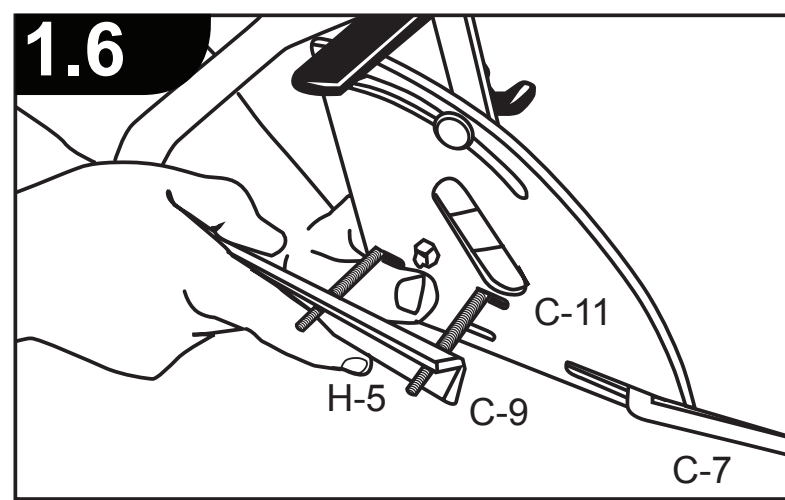
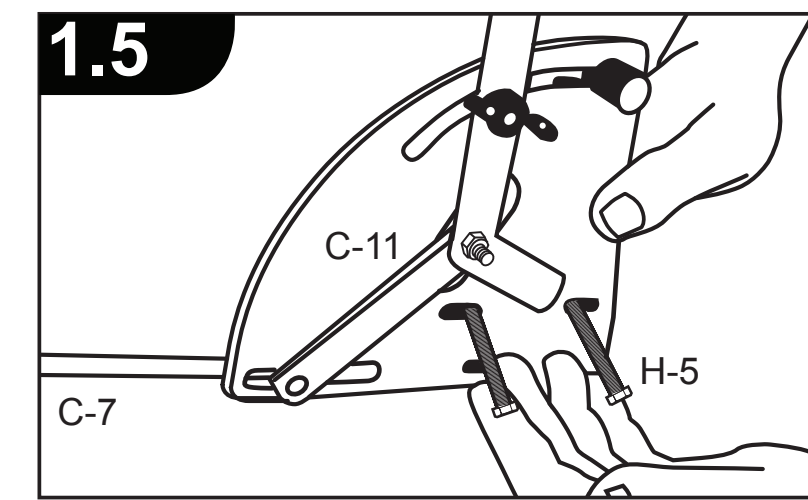
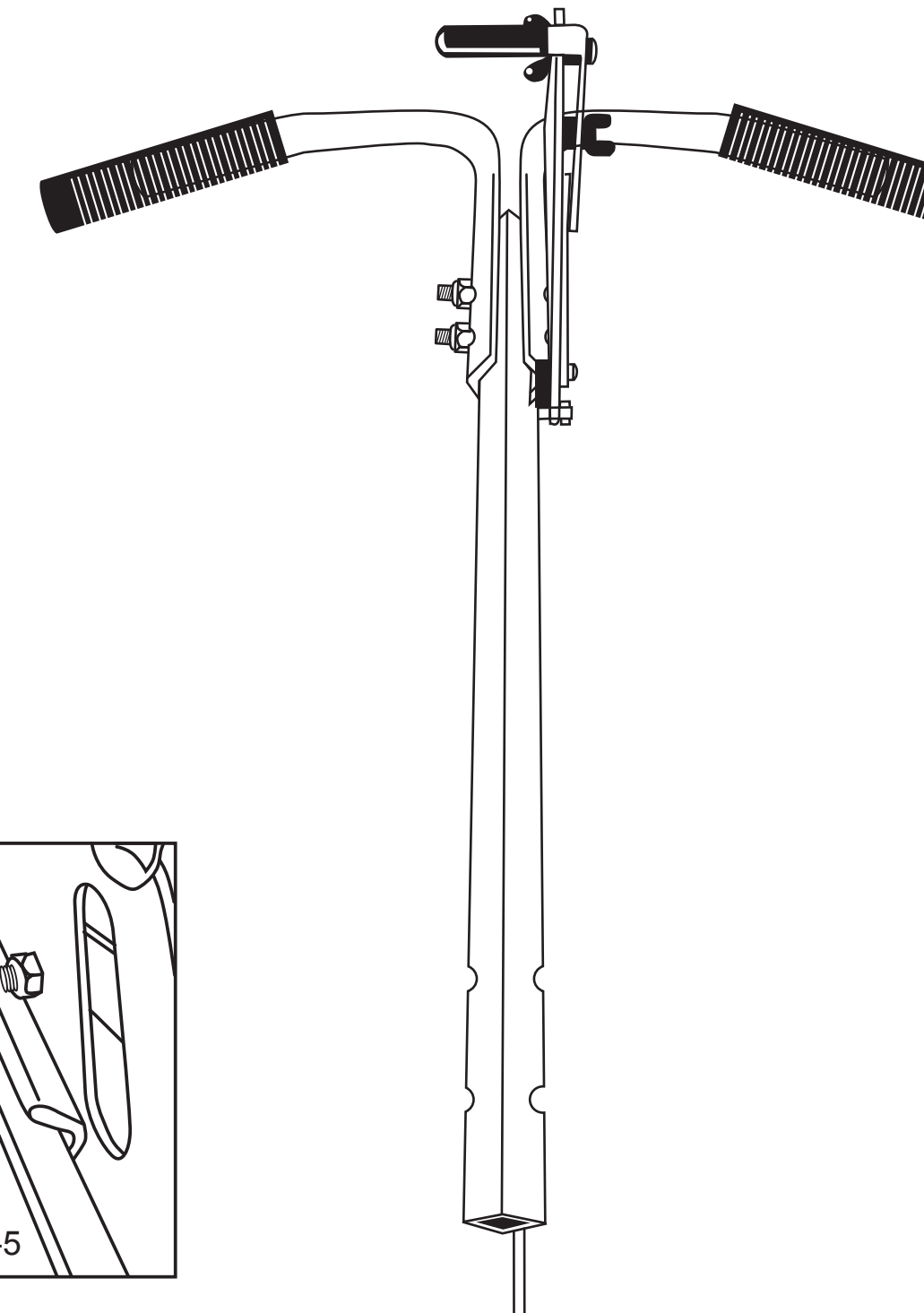

Note: When installing Gate control assembly (1.8), Tighten both screws enough to hold in place for adjustment of gate control later. (Step 4.7- 4.10)

Nota: Al instalar el conjunto de control de la compuerta (1.8), apriete ambos tornillos lo suficiente para sujetarlo en su sitio para ajustar posteriormente el control de la compuerta. (Paso 4.7 - 4.10)

Remarque: Lors de l'installation de la vanne de dégagement (1.8), serrez suffisamment les deux vis pour maintenir cette dernière en place et pouvoir l'ajuster plus tard. (Étape 4.7 à 4.10)

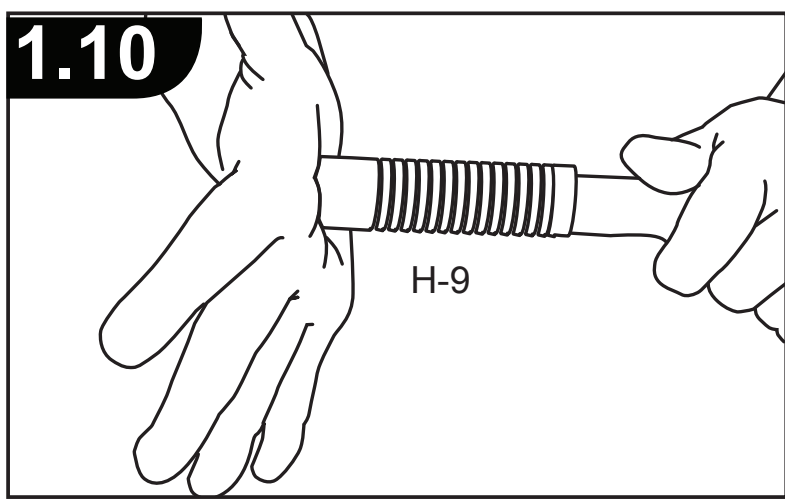
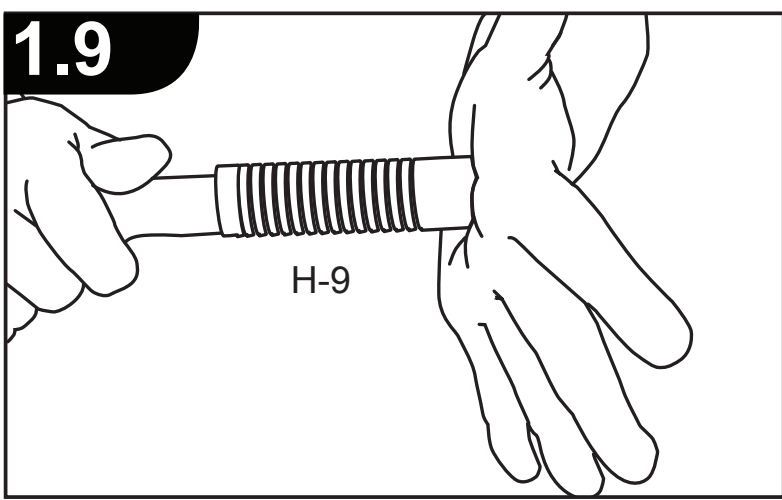

2 Frame Legs to Hopper assembly (2.1 - 2.4)

Unión de las patas de la estructura al ensamblaje de la tolva (2.1 - 2.4)

Montage des pattes à l'ensemble de la trémie (2.1 - 2.4)

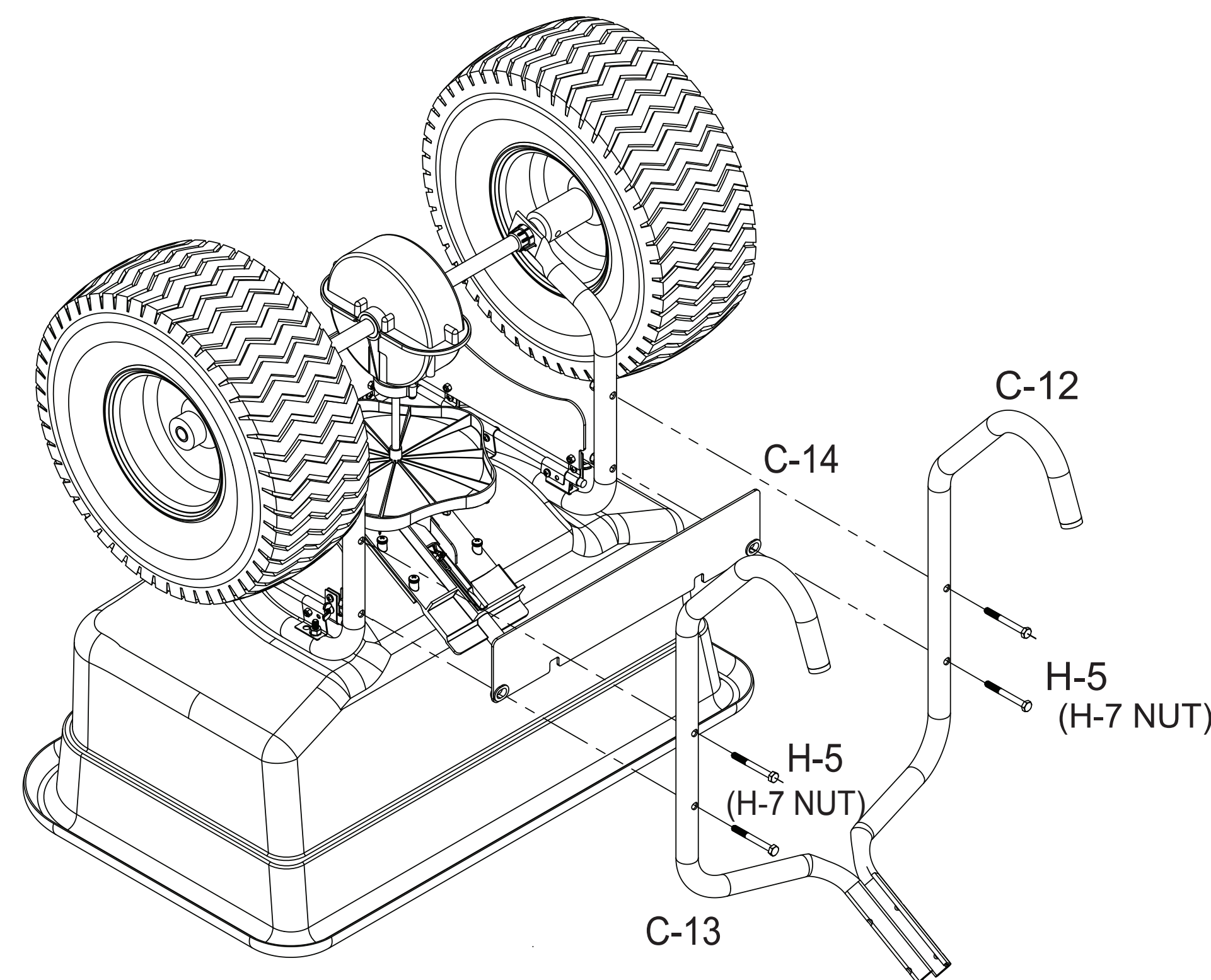
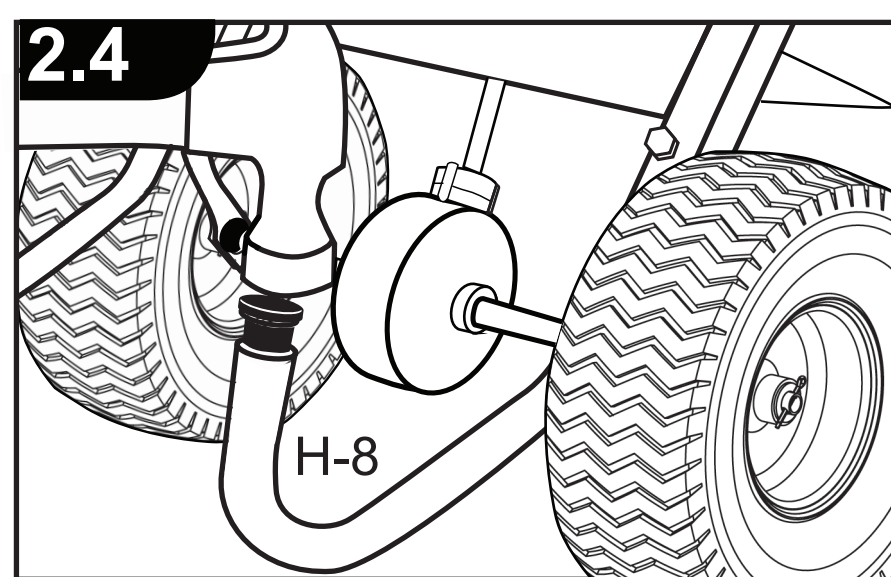
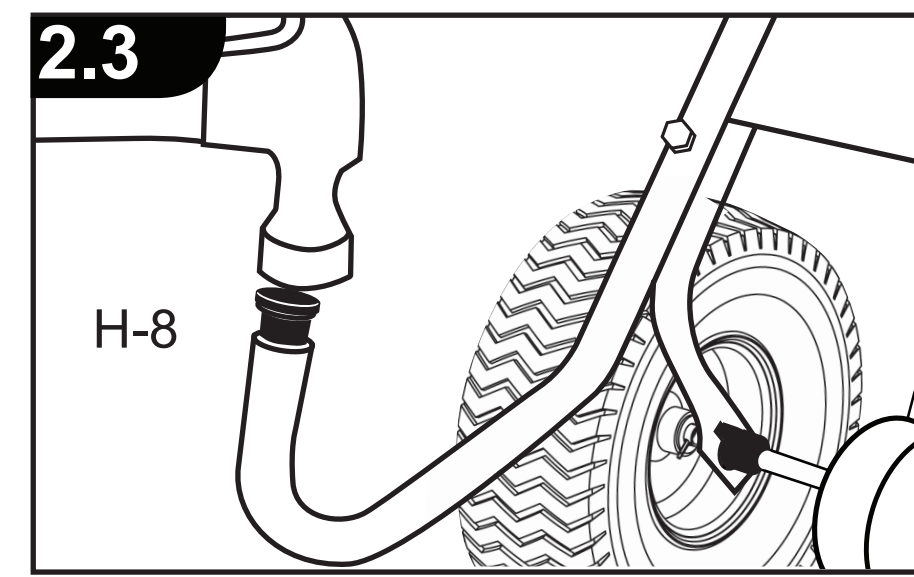
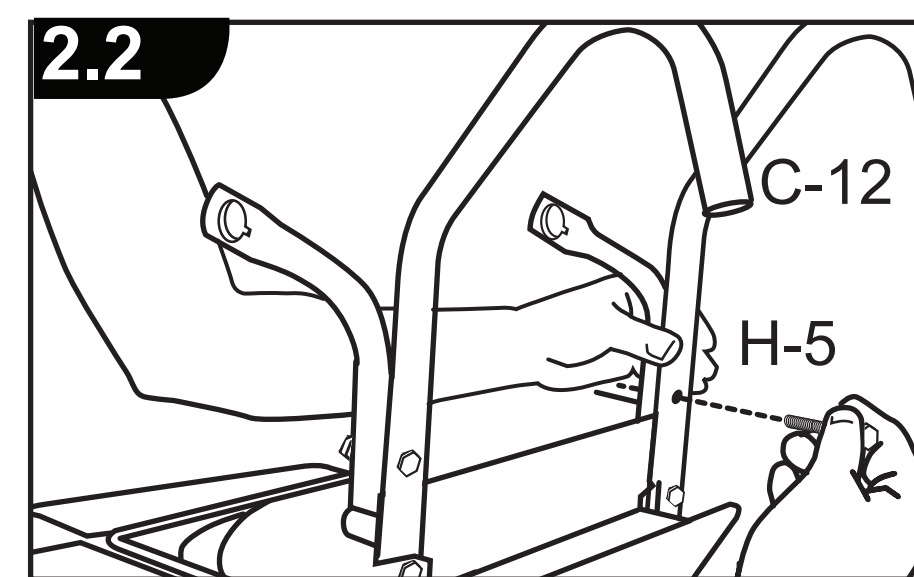
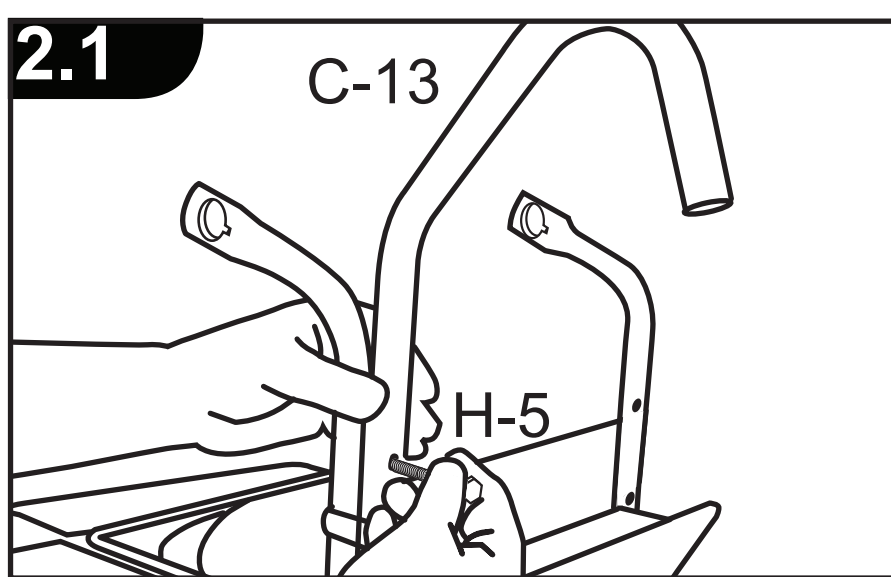

Completed Assembly
 Ensamblaje completo
 Assemblage terminé

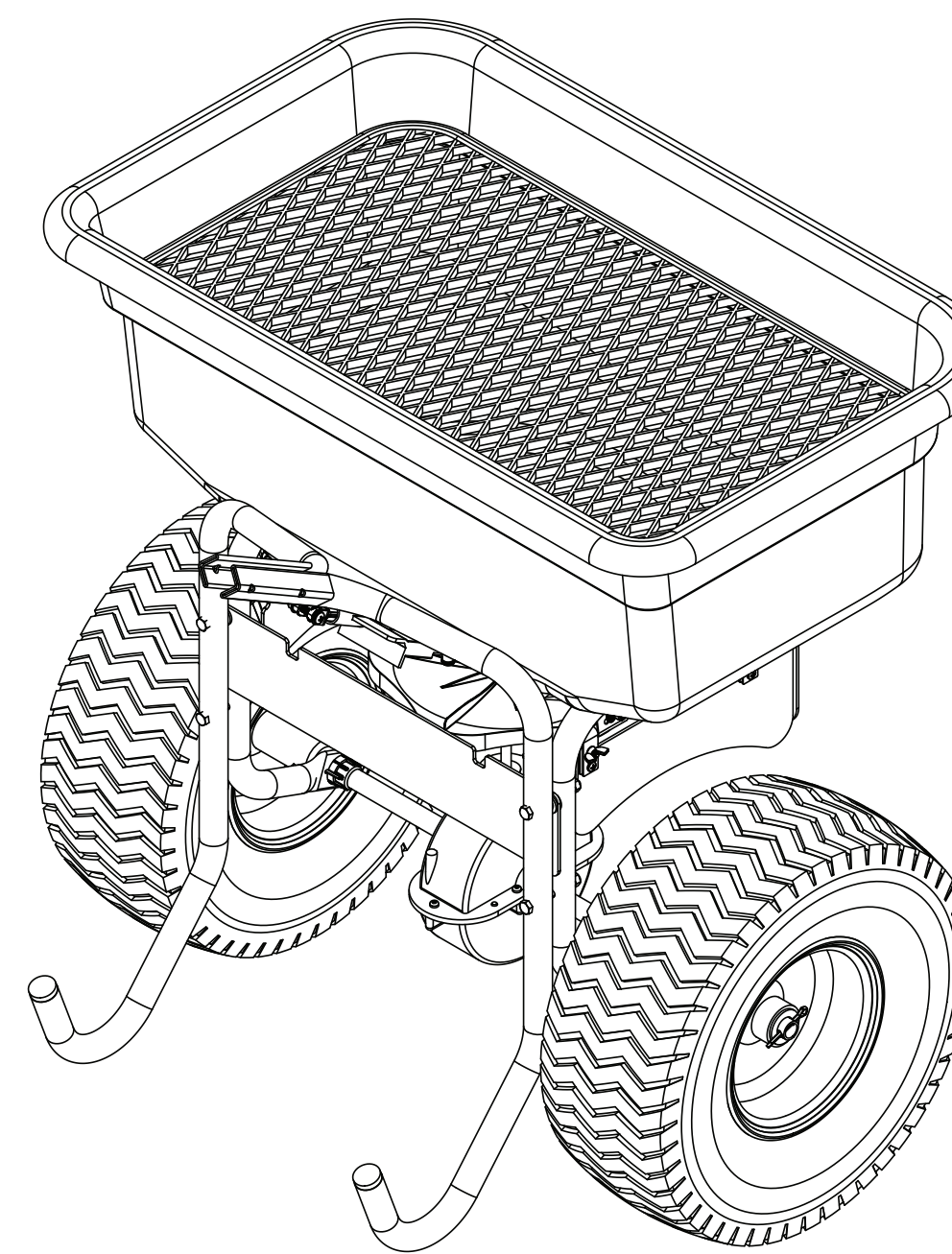

CHAPIN INTERNATIONAL, INC. P.O. BOX 549 700 ELLICOTT ST. BATAVIA, NY 14021-0549

CHAPIN

APPLICATION CHART

All Season Residential & Professional Application Guidelines	All Season Residential & Professional Push Spreader Application Conversion Chart																				
	Scotts	2	2.5	3	3.25	3.5	4	4.25	5	5.5	6	7	8	9	10	11	12	13	14	15	
Wheel Control	1-10																				
Fertilizer	11-12																				
Grass Seed - Overseeding	13-14																				
Grass Seed - New Lawn	16-17																				
Salt & Ice-Melt	18-20																				

TABLA DE APLICACIÓN

Aplicación General Profesional & Residencial para toda temporada Directrices	Tabla de conversión para la aplicación profesional y residencial del distribuidor de empuje para toda temporada																				
	Scotts	2	2.5	3	3.25	3.5	4	4.25	5	5.5	6	7	8	9	10	11	12	13	14	15	
Control de ruedas	1-10																				
Fertilizante	11-12																				
Siembra de pasto - Sobresiembr	13-14																				
Siembra de pasto - Césped nuevo	16-17																				
Sal y deshielo	18-20																				

TABLEAU D'APPLICATION

Directives d'application générale résidentielle et professionnelle toute saison	Tableau de conversion d'application pour épandeur à pousser résidentiel et professionnel toute saison																				
	Scotts	2	2.5	3	3.25	3.5	4	4.25	5	5.5	6	7	8	9	10	11	12	13	14	15	
Déshuage	1-10																				
Fertilisants	11-12																				
Graines de gazon - Sous-semence	13-14																				
Graines de gazon - Nouvelle pelouse	16-17																				
Sal et produit de déshuage	18-20																				

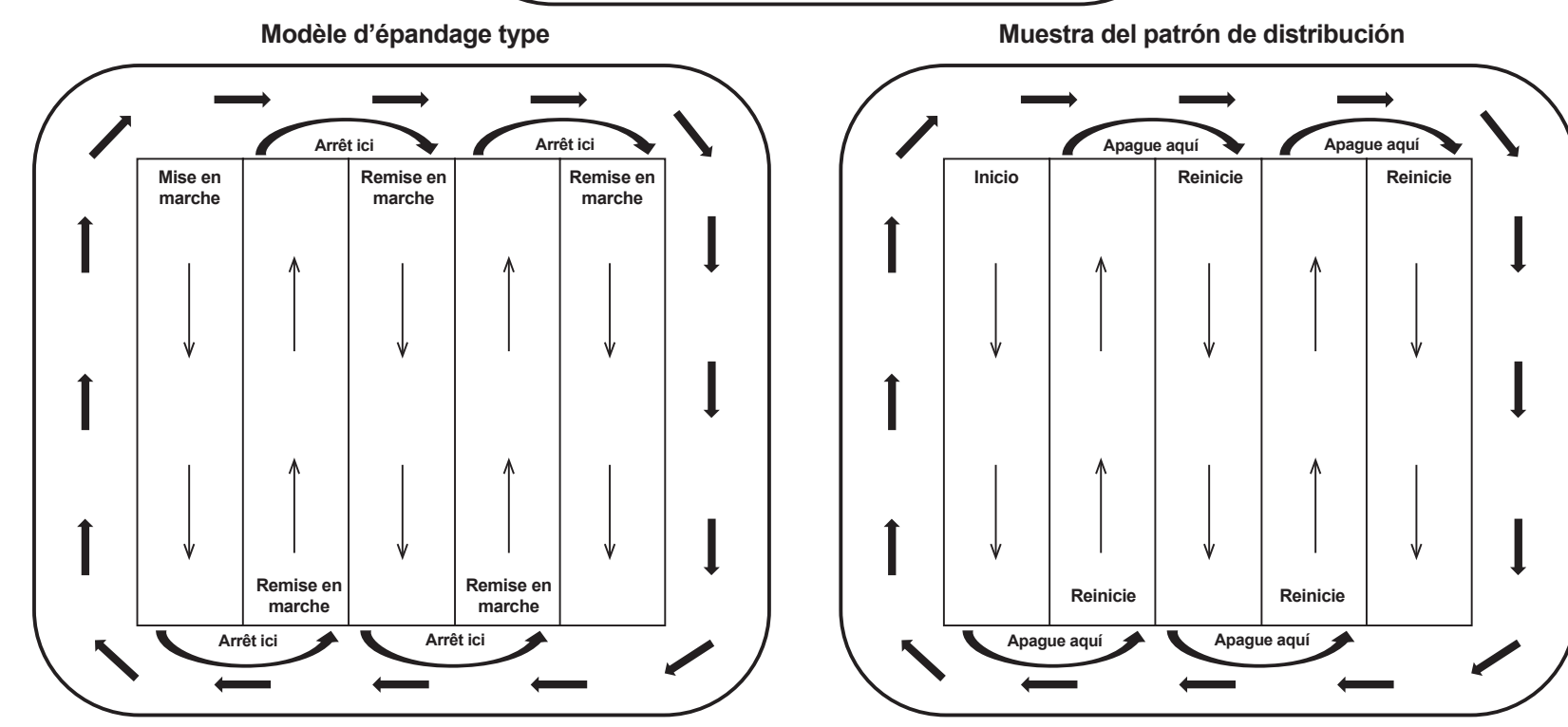
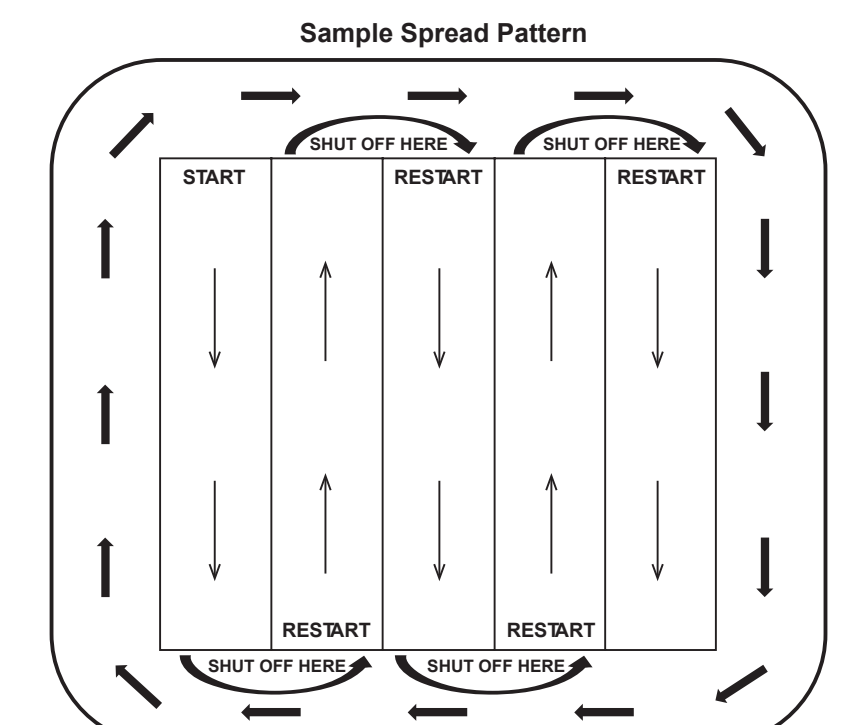

CHAPIN

FULL BAFFLE SPREADER ASSEMBLY INSTRUCTIONS
 ARMADO DEL ESPARCIDOR CON DEFLECTOR COMPLETO
 DIRECTIVES D'ASSEMBLAGE DU DÉFLECTEUR COMPLET



DO NOT RETURN TO STORE. CALL CHAPIN CUSTOMER SERVICE:
 NO DEVUELVAA LA TIENDA. LLAME A SERVICIO A CLIENTES DE CHAPIN:
 NE PAS RETOURNER EN MAGASIN APPELER LE SERVICE À LA CLIENTÈLE DE CHAPIN :
 800-950-4458
 www.chapinmfg.com
 013937 R 0715

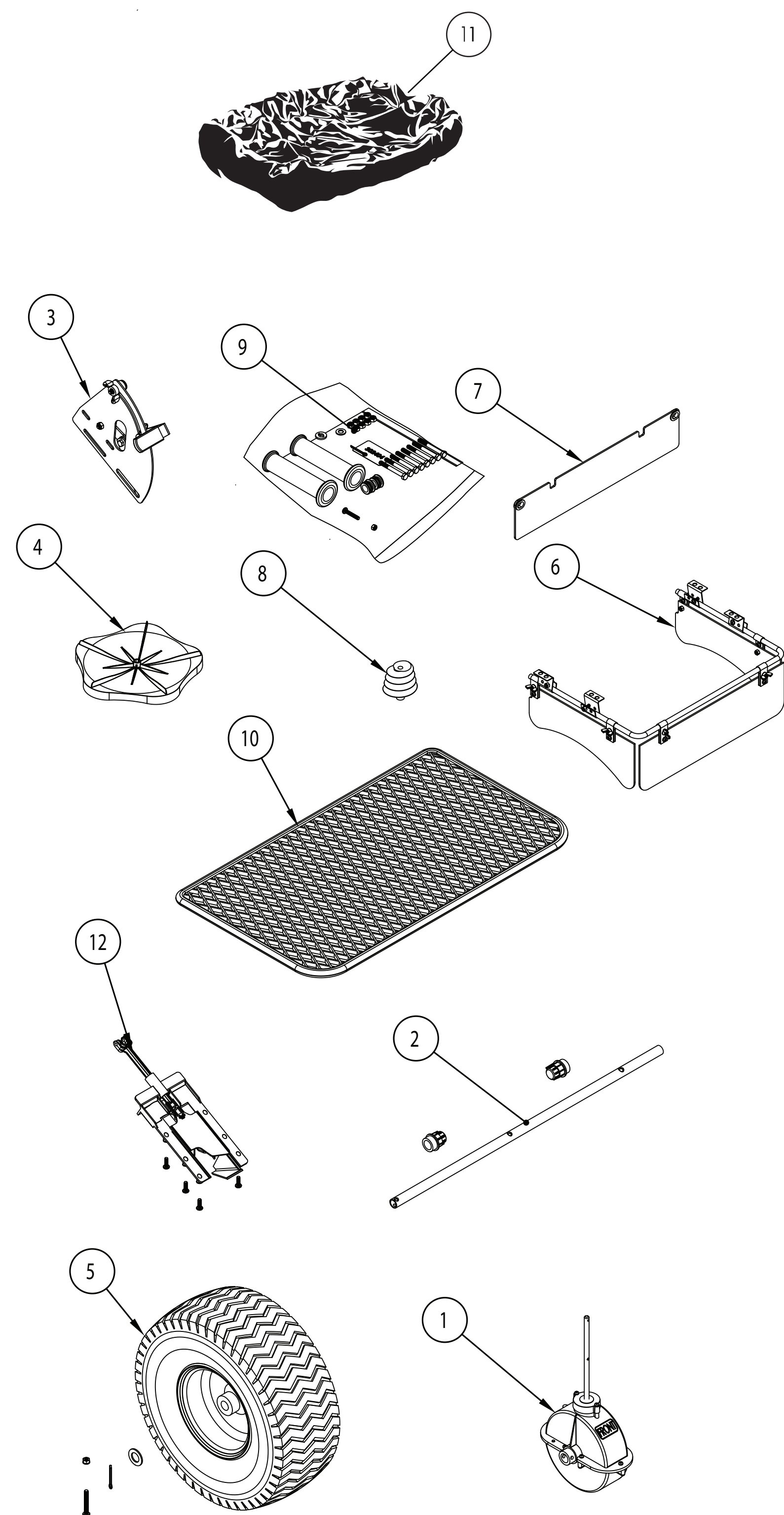

3

Handlebar Assembly to Hopper Frame / Auger Attachment For Salt Spreaders (3.1- 3.11)

Conjunto de la barra de manija al chasis de tolvilla / accesorio de tornillo sin fin para esparcidores de sal (3.1 - 3.11)

Installation du guidon à l'armature de la trémie / Vrille pour épandeurs de sel (de 3.1 à 3.11)

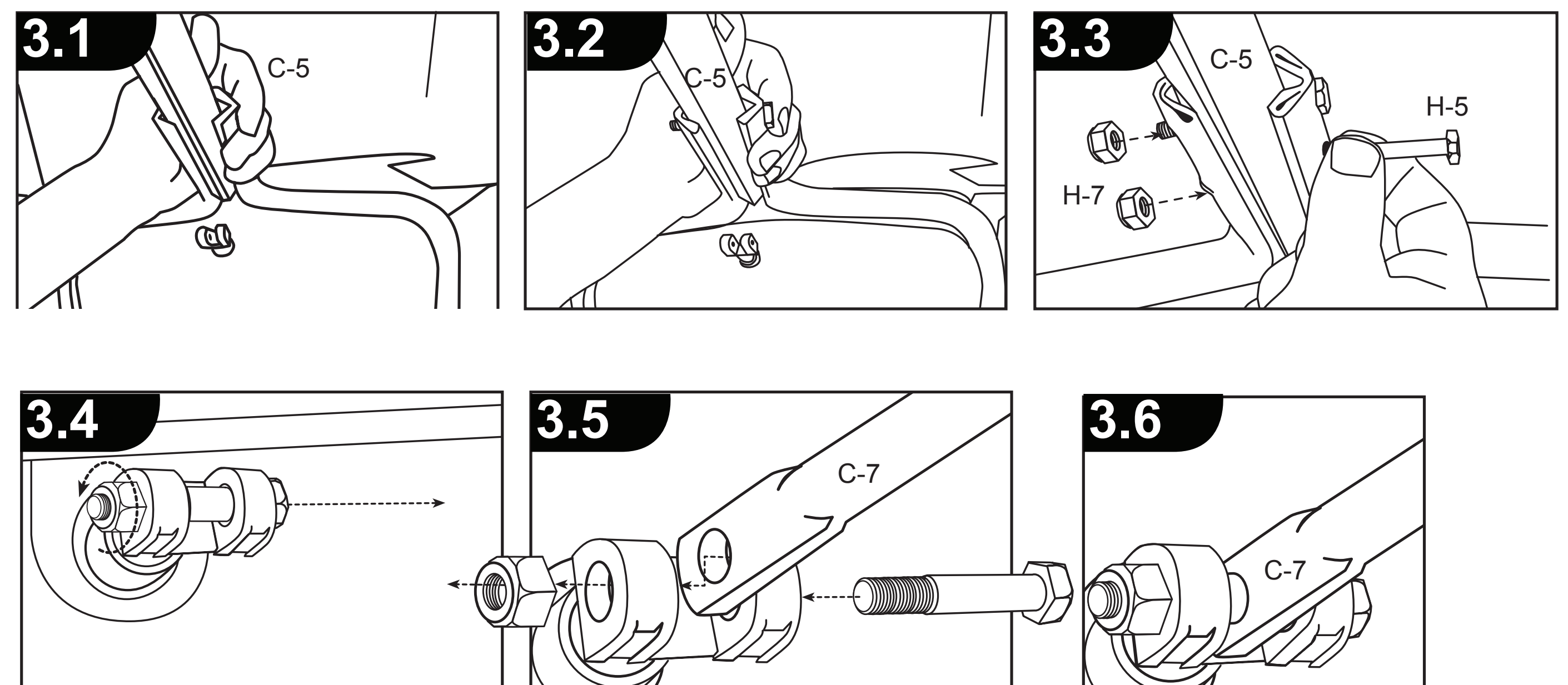
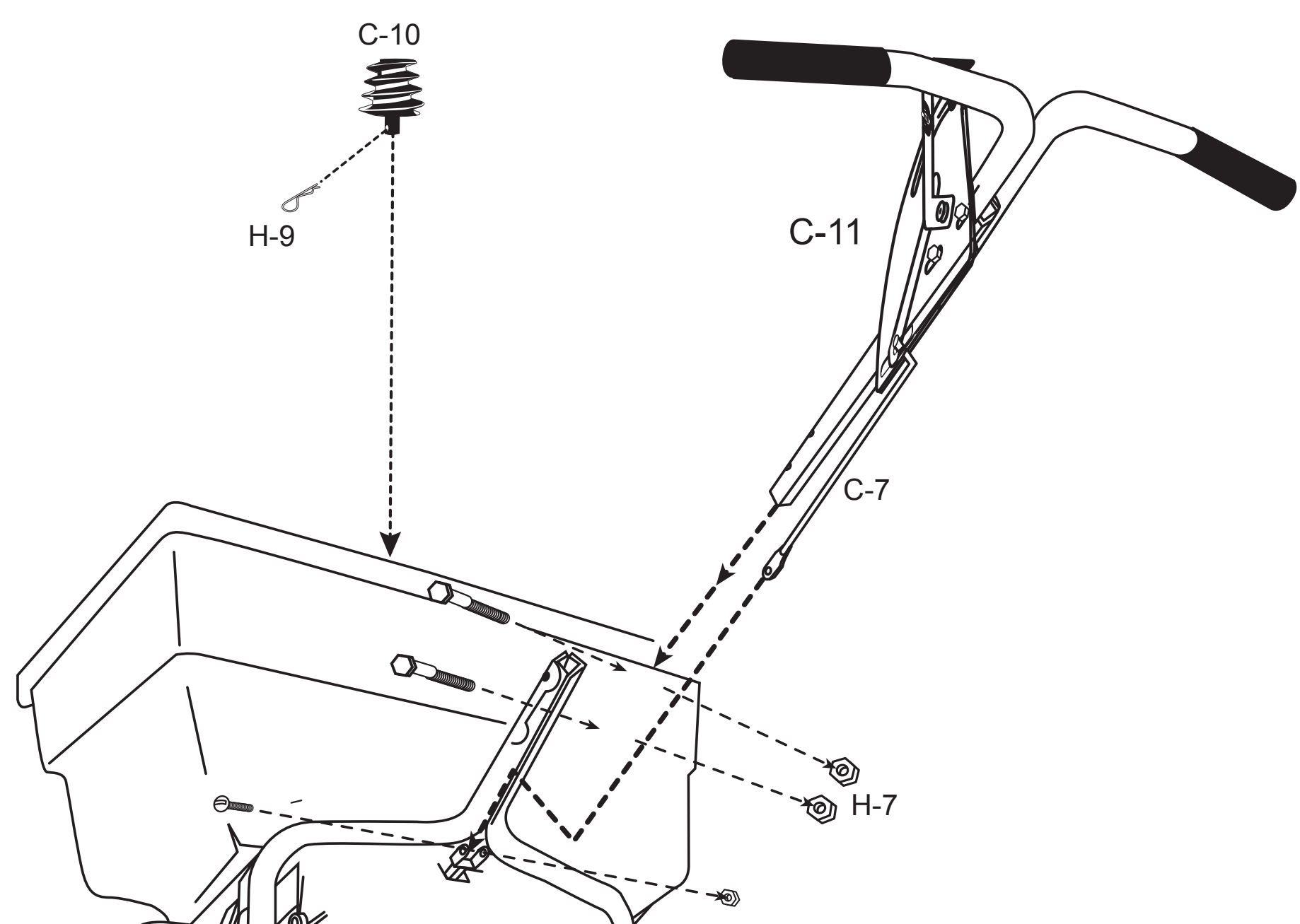

Remove nut and bolt for use in step 3.5 - 3.6
 Retire el pemo y tuerca para usarlos en el paso 3.5 - 3.6
 Enlevez le boulon et l'écrou utilisés aux étapes 3.5 à 3.6

Gate Adjustment and Auger Installation (Inside Hopper)

Instalación de ajuste de compuerta y tornillo sin fin (interior de la tolvilla)

Ajustement de la vanne et installation de la vrille (à l'intérieur de la trémie)

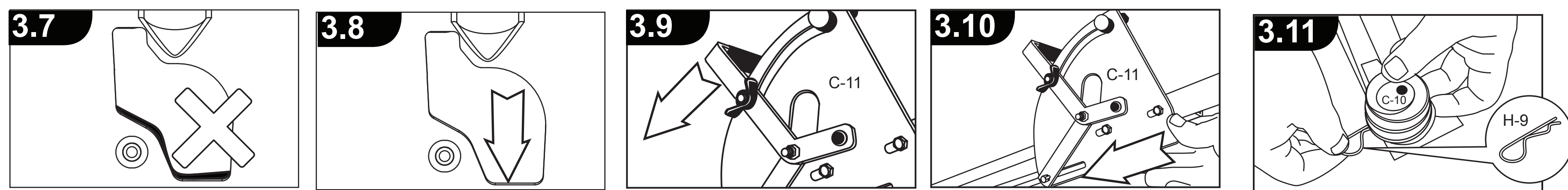

Note: Complete steps 3.7 - 3.10 only if gate isn't completely closed when lever is in forward position (as shown in 3.7). Once gate is adjusted, tighten both nuts on Gate Control Assembly (C-11).
Nota: Realice los pasos 3.7 - 3.10 solamente si la compuerta no está completamente cerrada cuando la palanca esté en posición hacia adelante (como se muestra en 3.7). Una vez que la compuerta está ajustada, apriete ambas tuercas en el conjunto de control de la compuerta (C-11).
Remarque : Ne suivez les étapes 3.7 à 3.10 que si la vanne n'est pas entièrement fermée lorsque le levier est en position avant (tel que montré à l'étape 3.7). Une fois la vanne ajustée, serrez les deux écrous sur la vanne de dégagement (C-11).

Final Step: After completing gate adjustment, tighten all assemblies before use.
Paso final: Después de completar el ajuste de compuerta, apriete todos los conjuntos antes de usar.
Étape finale : Une fois la vanne ajustée, serrez toutes pièces assemblées avant utilisation.



Auger is designed to work in forward motion. Excessive reverse motion could cause binding. If resistance is felt while pulling spreader backwards, stop and clear salt from auger.

El taladro se diseña para trabajar en la carrera útil. El movimiento reverso excesivo podría causar el atascamiento. Si se siente la resistencia mientras que tira del esparcidor al revés, de la parada y de la sal clara del taladro.

La foreuse est conçue pour fonctionner dans la marche avant. Le mouvement renversé excessif a pu entraîner l'attache. Si la résistance est sentie tout en tirant l'écarteur vers l'arrière, l'arrêt et le sel clair.

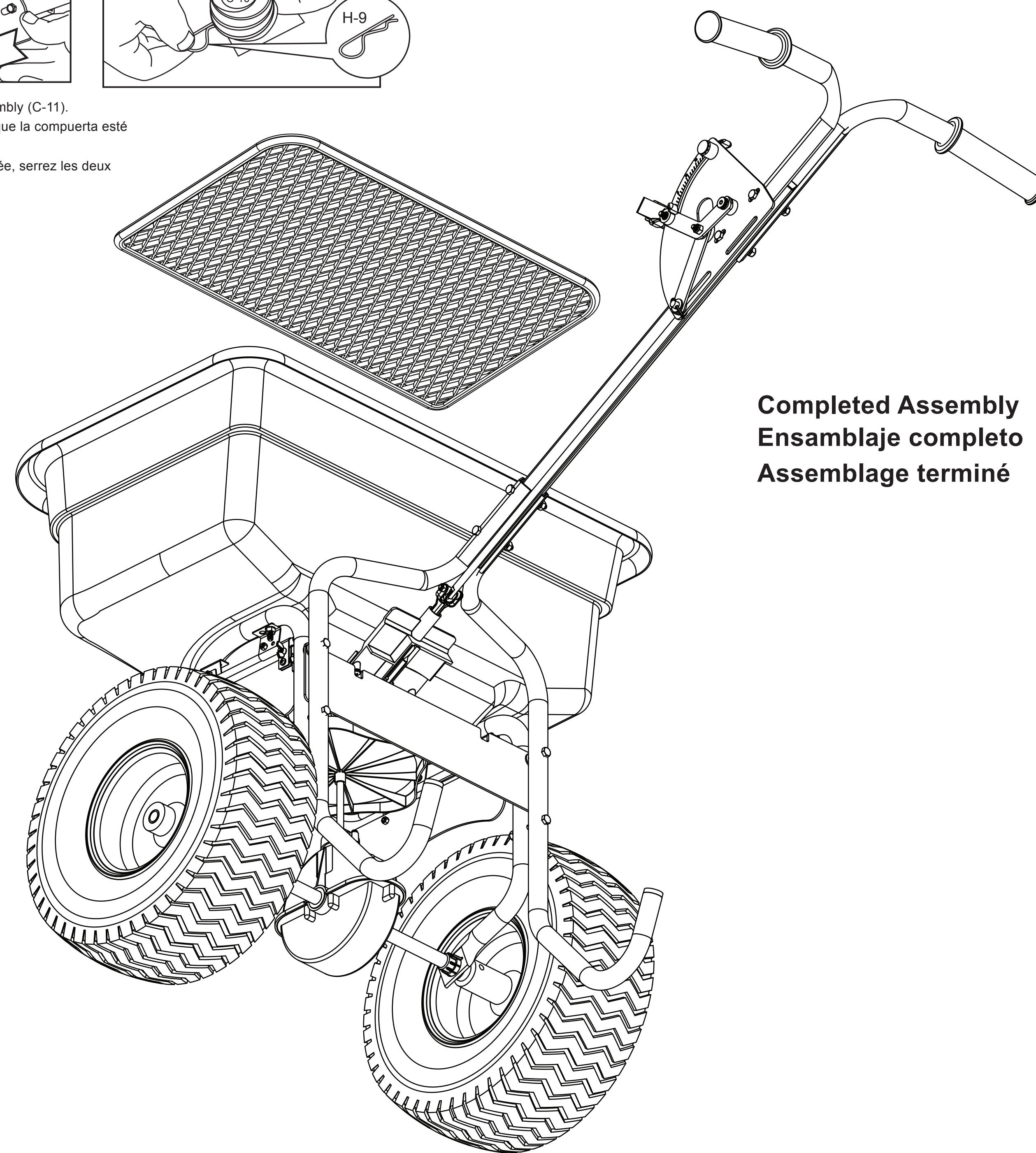

Ref.#	Qty	Part No.	Description / Descripción / Description
1	1	6-9031	Gear Box Assembly / Conjunto de la caja de engranes / Ensemble de la boîte d'engrenages
2	1	6-9009	Drive shaft w/2 bearings / Fletcha de transmisión c/2 conijnetes / Arbre de transmission avec 2 roulements
3	1	6-9038	Gate Control Assembly / Conjunto del control de la compuerta / Ensemble du contrôle de la vanne
4	1	6-9014	Impeller / impulsor / Roue à ailettes
5	1	6-9015	Wheels w/hardware / Ruedas C/herrajes / Roues avec matériel
6	1	6-9025	Salt Baffles / deflectores de la sal / Cloisons de sel
7	1	6-9055	Rear Baffle / Baffle posterior / Cloison arrière
8	1	6-9029	Auger / Taladro / Foreuse
9	1	6-9052	Hardware Bag / Bolsa de herrajes / Sac de matériel
10	1	6-9053	Grate / Parrilla / Grille
11	1	6-9054	Rain Cover / Cubierta para lluvia / Couverture protectrice contre la pluie
12	1	6-9051	Gate Assembly

CHAPIN CUSTOMER SERVICE: 800-950-4458