

Submittal Sheet

Model 100-SSC-R, 100-SSC-SM Clad Stainless Steel Diaper Changing Station

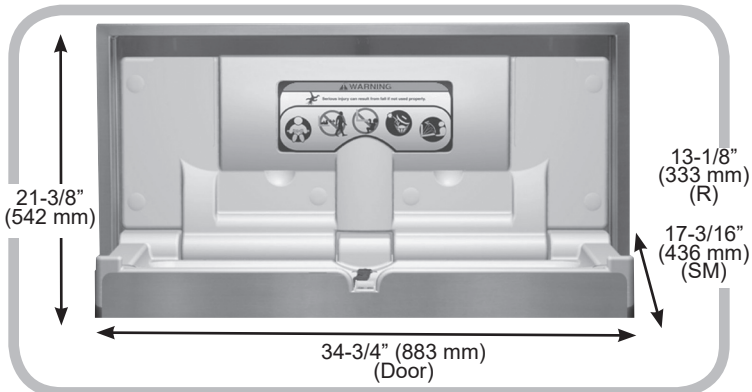

Recommended Blocking Recessed Mount

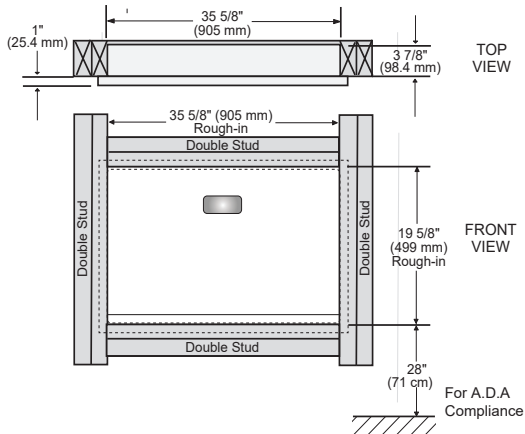

Recommended Blocking Surface Mount

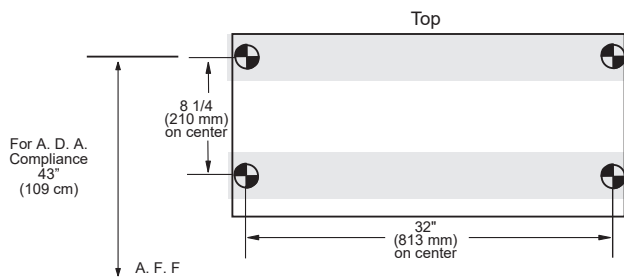

Installation Information

- 3.88" (98 mm) recessed into wall, 1" (25 mm) protrusion from wall. Unit projects 4" (100mm) when surface mounted (100-SSC-SM)
- Rough-in opening 35.625" (905mm) wide x 19.625" (499 mm) high. Shim as required for tight fit on all 4 sides. For recess mount, use side mounting holes.
- Open unit projects from wall 13-1/8" (333 mm) when recessed and 17-3/16" (436 mm) when surface mounted
- 3.5" (89 mm), 18 gauge metal studs minimum. Line studs with trimmed 2 x 4's.

- Polyethylene body with stainless steel exterior
- Easy to clean, high density polyethylene which is naturally bacteria resistant, beneath 304 brushed stainless steel encasement.
- Standard with molded-in dual liner dispensers.
- Each liner dispenser holds approximately 50 of the 036-LCR or 036-NWL liners.
- A.D.A. cam-buckle is adjustable with one hand.
- Smooth nylon safety belt is easily cleaned and does not harbor bacteria
- Convenient bag hooks clearly labeled on both sides
- Easy to read ANSI compliant labels (ANSI Z535.3 and ANSI Z535.4), utilizing universal safety symbols
- Compact, slim profile meets A.D.A. Only protrudes 4 inches or 102 mm from wall
- Includes universal changing station door sign
- Pneumatic gas shock mechanism to ensure smooth, safe open and close motions.
- Includes easy to install, step-by-step instructions plus all mounting hardware
- ASTM G21 Anti-Fungal: No measurable fungal growth
- Meets or exceeds ASTM F2285 Safety Specifications for Commercial Changing Stations.
- Standard pack: 1 unit
- Limited Warranty: This product is warranted against manufacturing defects for a period of 5 years.

Short Specifications

Polyethylene Diaper Changing Stations with Stainless Steel Exterior:

1. Acceptable Products: Foundations Worldwide Inc. Model 100-SSC-R (Clad Horizontal Recessed Mount) & 100-SSC-SM (Clad Horizontal Surface Mount)
2. Characteristics:
 - a. Entire body 16 gauge, 304 brushed stainless steel, seamless welds
 - b. Provide Foundations Worldwide Inc. SS flange in order to surface mount unit
 - c. Provide Foundations Worldwide Inc. 200-SSLD; stainless steel liner dispenser
3. Equipped with a pneumatic cylinder
4. Smooth nylon safety belt is easily cleaned
5. Meets ASTM F2285 requirements for weight bearing changing stations
6. **A.D.A. Compliance:**

306.3	Knee Clearance
307.2	Maximum Protruding Objects
308.2	Forward Reach
308.3	Side Reach
309.4	Operation
902.3	Work Surface

Compliant when properly installed.
7. ANSI compliant safety labels
8. CPSIA compliant to applicable sections

