

WAVEBRAKE® DIRTY WATER BUCKET

Keeping the dirty water separate from clean water, the dirty water bucket helps to reduce the potential for cross-contamination. Executive Series™ WaveBrake® includes the dirty water bucket as standard.

Features and Benefits:

- Nests below the wringer to keep dirty water separate from clean
- Bucket is removable, making it easy to empty

Colors Available:

- Red, Yellow, Gray

Material Composition:

- High-pressure injection-molded plastic
- Bail handle is steel

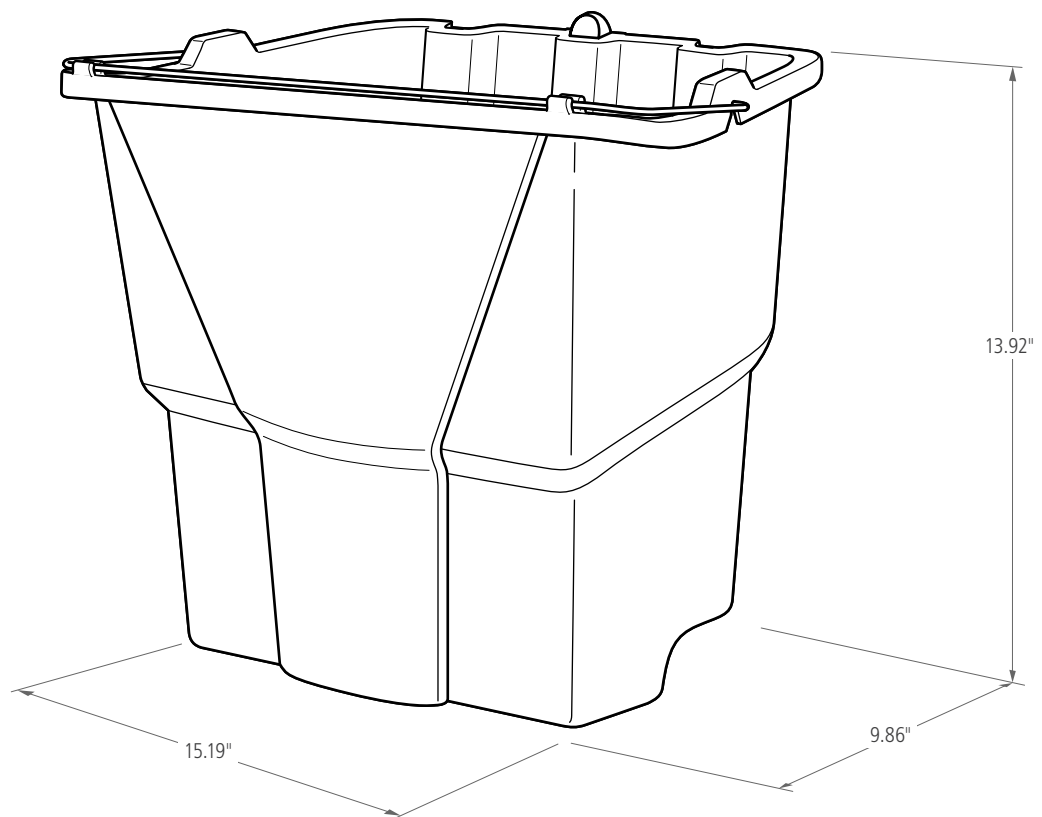

Unit Packaged Dimensions

SKU #	DESCRIPTION	COLOR	CAPACITY	LENGTH	WIDTH	HEIGHT	WEIGHT	CASE QTY
			QT	IN	IN	IN	LB	
2064907	35-QT WAVEBRAKE® DIRTY WATER BUCKET	RED	16	9.86	15.19	13.92	2.25	6
2064908	35-QT WAVEBRAKE® DIRTY WATER BUCKET	YELLOW	16	9.86	15.19	13.92	2.25	6
2064905	35-QT WAVEBRAKE® DIRTY WATER BUCKET	GRAY	16	9.86	15.19	13.92	2.25	6

