



**MAXIMIZER™**

# QUICK CHANGE CLEANING TOOLS



## SWITCH TOOLS IN LESS TIME

Make routine cleaning faster by switching between tools in less time.



## TOOLS FOR COMMON JOBS

Select from a microfiber frame, duster, squeegee, scrub brush, and floor prep tool. Add a storage tray for convenient access.



## INCREASED ACCESSIBILITY

Increase accessibility to frequently used cleaning tools by adding onboard storage to current carts.





## Maximizer™ Quick Change Tools

SKU #	CUST. ITEM #	DESCRIPTION	COLOR	LENGTH	WIDTH	HEIGHT	WEIGHT	CASE QTY
2018788		MAXIMIZER™ QUICK CHANGE STORAGE TRAY	BLACK	24.75	19.75	4.13	4.57	1
2018789		MAXIMIZER™ QUICK CHANGE EXTENSION HANDLE	YELLOW	35.50	1.75	1.63	0.84	12
2018790		MAXIMIZER™ QUICK CHANGE DUSTER	BLACK	25.88	2.13	1.25	0.36	6
2018801		MAXIMIZER™ QUICK CHANGE SQUEEGEE	BLACK	13.13	10.13	2.06	0.39	6
2018802		MAXIMIZER™ QUICK CHANGE SCRUB BRUSH	BLACK	11.38	6.00	2.63	0.40	6
2018803		MAXIMIZER™ QUICK CHANGE FLOOR PREP TOOL	BLACK	9.00	4.75	4.75	0.46	6
2018804		MAXIMIZER™ QUICK CHANGE MICROFIBER FRAME	BLACK	17.00	3.25	1.50	0.60	6
2018805		MAXIMIZER™ QUICK CHANGE CLEANING KIT	BLACK	37.00	7.75	3.19	2.21	1

## Additional Maximizer™ Products

SKU #	CUST. ITEM #	DESCRIPTION	COLOR	LENGTH	WIDTH	HEIGHT	WEIGHT	CASE QTY
2018727		MAXIMIZER™ PUSH-TO-CENTER BROOM – 18" MP	BLACK	58.13	8.25	7.75	2.50	6
2018728		MAXIMIZER™ PUSH-TO-CENTER BROOM – 36" MP	BLACK	58.13	8.25	8.75	3.30	6
2018729		MAXIMIZER™ PUSH-TO-CENTER BROOM – 18" FINE	BLACK	58.13	8.25	7.75	2.50	6
2018730		MAXIMIZER™ PUSH-TO-CENTER BROOM – 36" FINE	BLACK	58.13	8.25	8.75	3.30	6
2018781		MAXIMIZER™ HD STAND UP DEBRIS PAN	BLACK	29.00	20.44	11.00	3.90	4
2018782		MAXIMIZER™ 3-IN-1 FLOOR PREP TOOL	BLACK	57.00	4.75	4.75	1.21	6
2018784		MAXIMIZER™ 3-IN-1 SCRUBBER PAD	BLACK	2.63	1.38	0.25	0.01	12
2018786		MAXIMIZER™ 3-IN-1 SCUFF REMOVER PAD	BLACK	2.63	1.38	0.50	0.01	12
2018787		MAXIMIZER™ 3-IN-1 REPLACEABLE SCRAPER	BLACK	2.63	1.50	0.81	0.05	12
2018806		MAXIMIZER™ WET/DRY DEBRIS PAN	BLACK	29.00	16.88	12.00	3.20	4
2018807		MAXIMIZER™ DOUBLE SIDED BROOM/SQUEEGEE	BLACK	44.50	4.13	7.00	1.40	8
2018808		MAXIMIZER™ DUST FRM, HNDL, SCRAPER – 24"	BLACK	57.00	5.50	1.75	1.85	6
2018809		MAXIMIZER™ DUST FRM, HNDL, SCRAPER – 36"	BLACK	57.00	5.50	1.75	2.60	6
2018810		MAXIMIZER™ DUST MOP PAD – 24"	YELLOW	25.25	5.50	0.50	1.19	12
2018821		MAXIMIZER™ DUST MOP PAD – 36"	YELLOW	37.25	5.50	0.50	1.72	12
2018822		MAXIMIZER™ EZ ACCESS SCRAPER – REPLACEMENT	BLACK	6.56	1.63	1.63	0.19	12
2018823		MAXIMIZER™ QUICK CHANGE FIXED HANDLE	YELLOW	57.00	1.50	1.50	0.73	12
2018824		MAXIMIZER™ OVERHEAD CLEANING TOOL	BLACK	71.50	3.50	2.38	2.50	6
2018825		MF OVERHEAD CLEANING TOOL WINDOW PAD	BLUE	12.63	5.25	0.19	0.09	6



©2017 Rubbermaid Commercial Products LLC  
8900 Northpointe Executive Park Drive, Huntersville, NC 28078

To see our complete range of cleaning solutions visit our online catalog at [RubbermaidCommercial.com](http://RubbermaidCommercial.com)

**MAXIMIZER™**



# MAXIMIZER™

The new Maximizer™ cleaning tools from Rubbermaid Commercial Products help workers save time by reducing steps in a task, reducing the time of a step and reducing user effort. Engineered to last and designed to perform in a variety of common spaces, Maximizer™ cleaning tools deliver fast, consistent results shift after shift.

## Features and Benefits:

- Constructed of high-strength ABS material, durable enough to stand up to everyday use
- Compact design fits easily on most housekeeping and cleaning carts
- Built-in compartments house up to 3 different tool attachments:
  - Top Shelf: Quick Change Microfiber Frame
  - Middle Shelf: Quick Change Duster Frame
  - Bottom Shelf: Quick Change Squeegee, Scrub Brush
- Easily installed to compatible Rubbermaid Commercial carts with enclosed hardware (instructions included):
  - MFG #s: FG9T7400, FG9T7200, FG9T7500, 1860740, 1805985, FG9T9200, FG9T93010000, FG9T8000, FG9T7700, FG9T7600, FG9T7800

# QUICK CHANGE STORAGE TRAY

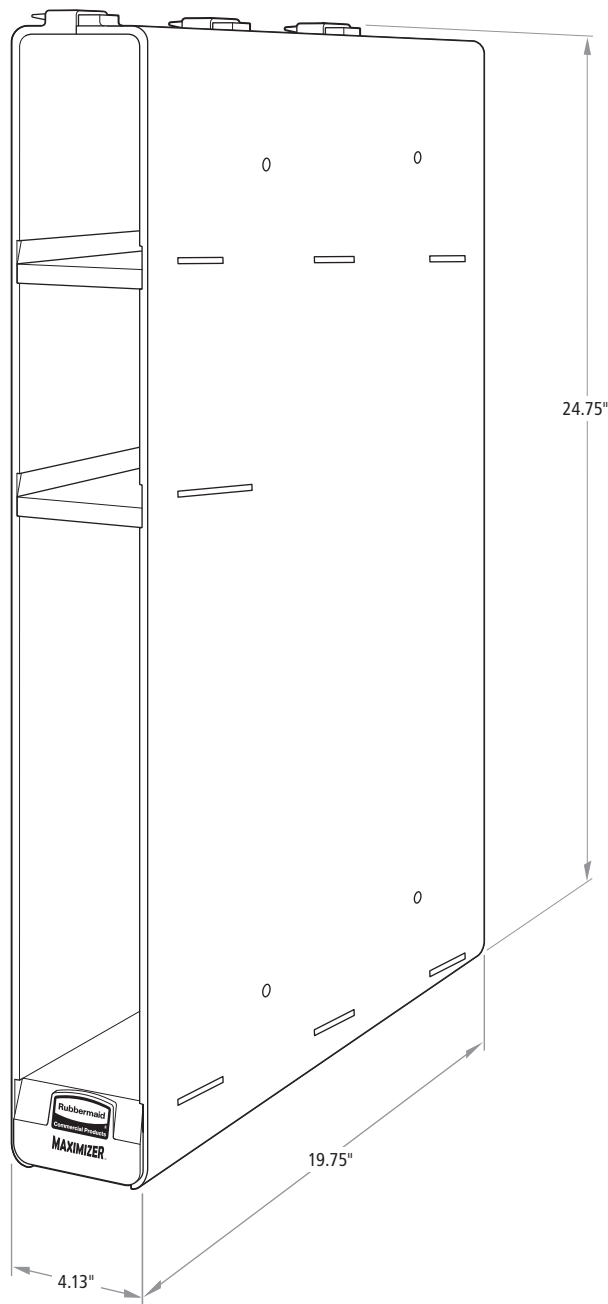

## Unit Packaged Dimensions

SKU #	DESCRIPTION	COLOR	LENGTH IN	WIDTH IN	HEIGHT IN	WEIGHT LB	PACK SIZE
2018788	MAXIMIZER™ QUICK CHANGE STORAGE TRAY	BLACK	24.75	19.75	4.13	4.57	1





# MAXIMIZER™

The new Maximizer™ cleaning tools from Rubbermaid Commercial Products help workers save time by reducing steps in a task, reducing the time of a step and reducing user effort. Engineered to last and designed to perform in a variety of common spaces, Maximizer™ cleaning tools deliver fast, consistent results shift after shift.

## Features and Benefits:

- Squeegee easily connects to the Maximizer™ Quick Change Handle (sold separately)
- EVA foam rubber blades designed for easy removal of liquids
- Stores easily in Maximizer™ storage tray

# QUICK CHANGE SQUEEGEE

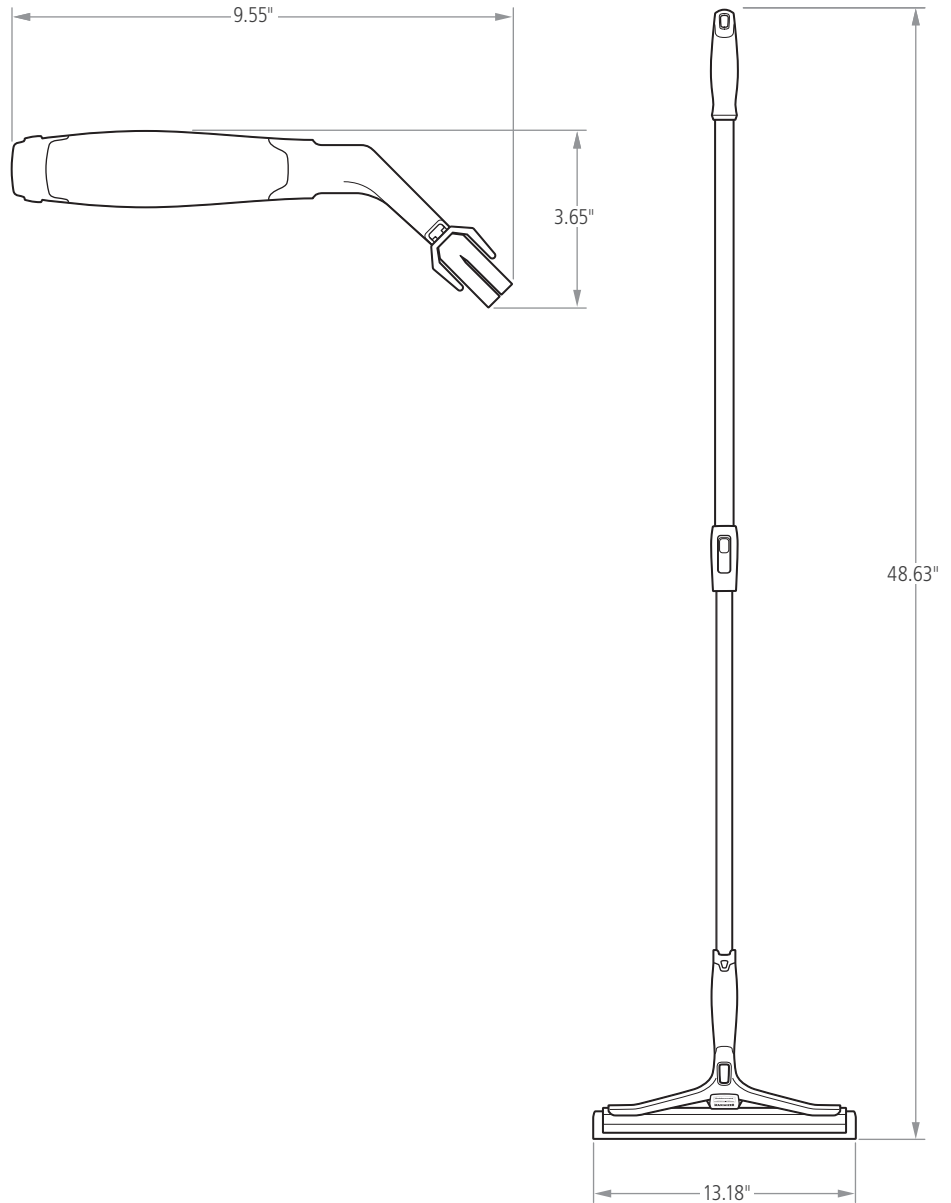

### Unit Packaged Dimensions

SKU #	DESCRIPTION	COLOR	LENGTH IN	WIDTH IN	HEIGHT IN	WEIGHT LB	PACK SIZE
2018801	MAXIMIZER™ QUICK CHANGE SQUEEGEE	BLACK	13.13	10.13	2.06	0.40	6
2018789	MAXIMIZER™ QUICK CHANGE EXTENSION HANDLE	YELLOW	35.50	1.75	1.63	0.84	12





# MAXIMIZER™

The new Maximizer™ cleaning tools from Rubbermaid Commercial Products help workers save time by reducing steps in a task, reducing the time of a step and reducing user effort. Engineered to last and designed to perform in a variety of common spaces, Maximizer™ cleaning tools deliver fast, consistent results shift after shift.

## Features and Benefits:

- Scrub Brush easily connects to the Maximizer™ Quick Change Handle (sold separately)
- Durable polypropylene bristles retain shape through repeated use
- Effective on indoor and outdoor surfaces
- Stores easily in Maximizer™ storage tray

# QUICK CHANGE SCRUB BRUSH

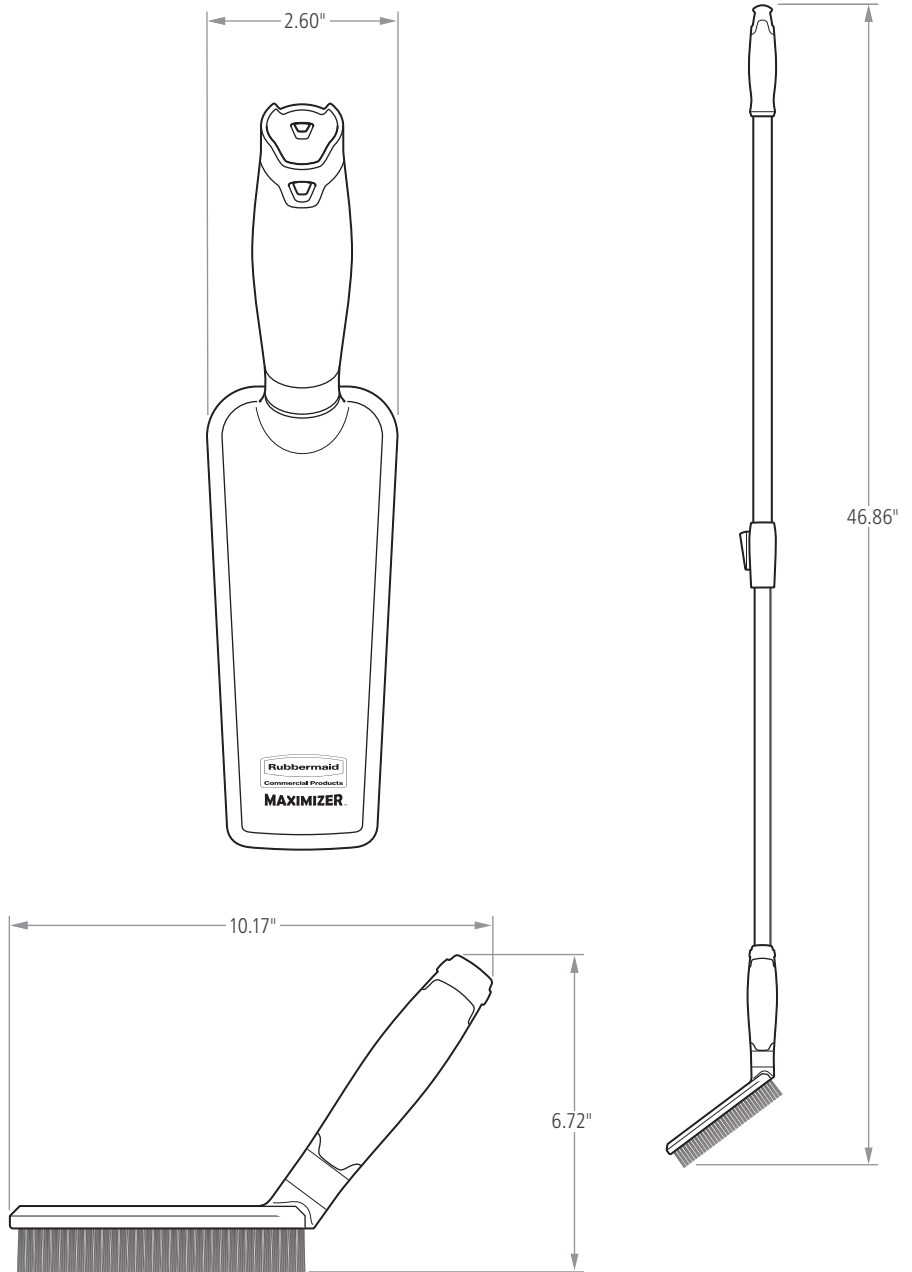

### Unit Packaged Dimensions

SKU #	DESCRIPTION	COLOR	LENGTH IN	WIDTH IN	HEIGHT IN	WEIGHT LB	PACK SIZE
2018802	MAXIMIZER™ QUICK CHANGE SCRUB BRUSH	BLACK	11.36	6.00	2.63	0.40	6
2018789	MAXIMIZER™ QUICK CHANGE EXTENSION HANDLE	YELLOW	35.50	1.75	1.63	0.84	12





# MAXIMIZER™

The new Maximizer™ cleaning tools from Rubbermaid Commercial Products help workers save time by reducing steps in a task, reducing the time of a step and reducing user effort. Engineered to last and designed to perform in a variety of common spaces, Maximizer™ cleaning tools deliver fast, consistent results shift after shift.

## Features and Benefits:

- Microfiber Frame easily connects to the Maximizer™ Quick Change Handle (sold separately)
- Frame accepts 18" Rubbermaid Commercial Products microfiber pads (sold separately)
- Flat profile easily slides under furniture and equipment
- Stores easily in Maximizer™ storage tray

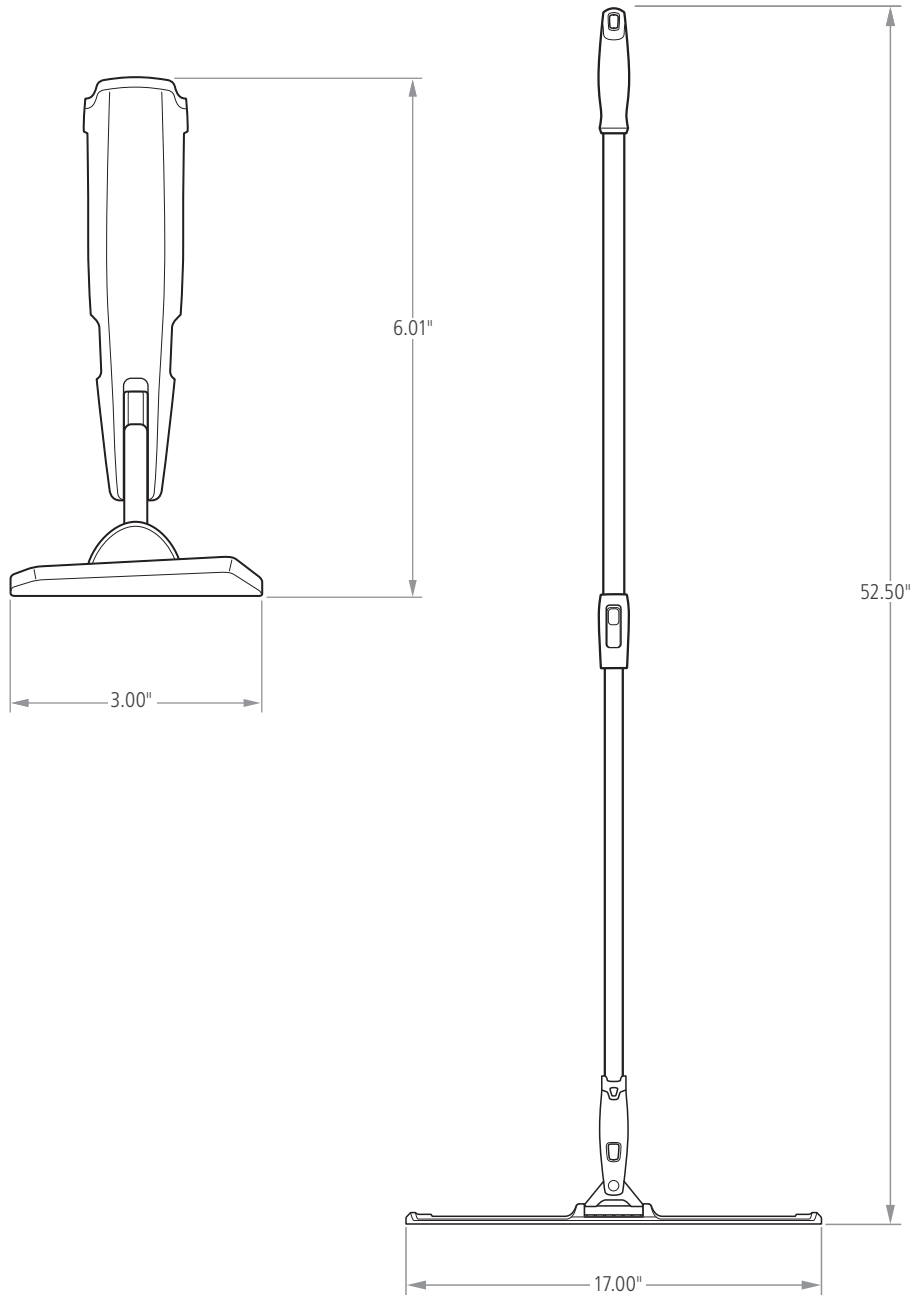

### Unit Packaged Dimensions

SKU #	DESCRIPTION	COLOR	LENGTH IN	WIDTH IN	HEIGHT IN	WEIGHT LB	PACK SIZE
2018804	MAXIMIZER™ QUICK CHANGE MICROFIBER FRAME	BLACK	17.00	3.25	1.50	0.60	6
2018789	MAXIMIZER™ QUICK CHANGE EXTENSION HANDLE	YELLOW	35.50	1.75	1.63	0.84	12





# MAXIMIZER™

The new Maximizer™ cleaning tools from Rubbermaid Commercial Products help workers save time by reducing steps in a task, reducing the time of a step and reducing user effort. Engineered to last and designed to perform in a variety of common spaces, Maximizer™ cleaning tools deliver fast, consistent results shift after shift.

## Features and Benefits:

- 3-in-1 Floor Prep Tool easily connects to the Maximizer™ Quick Change Handle (sold separately)
- Tools include:
  - Medium Scrubber Pad
    - Designed for general cleaning
    - Constructed of durable polyester fibers for long life
  - Scuff Remover Pad
    - Lifts stubborn floor scuffs left behind by traditional cleaning tools
    - Made of durable polyester fibers and EVA foam rubber for long life
  - Replaceable Scraper
    - Removes dry, stuck-on debris left behind by traditional cleaning tools
    - Constructed of high strength ABS material for long life

# QUICK CHANGE FLOOR PREP TOOL

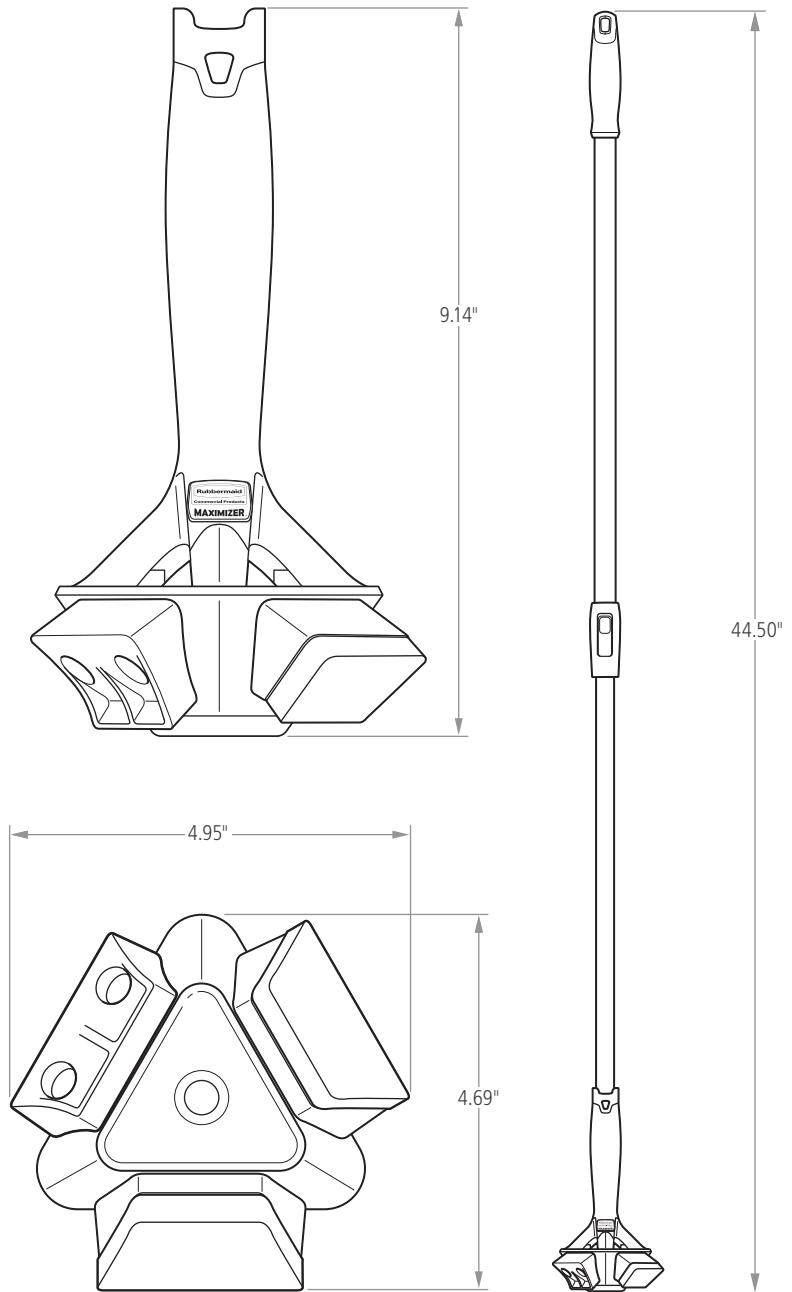

## Unit Packaged Dimensions

SKU #	DESCRIPTION	COLOR	LENGTH IN	WIDTH IN	HEIGHT IN	WEIGHT LB	PACK SIZE
2018803	MAXIMIZER™ QUICK CHANGE FLOOR PREP TOOL	BLACK	9.00	4.75	4.75	0.46	6
2018789	MAXIMIZER™ QUICK CHANGE EXTENSION HANDLE	YELLOW	35.50	1.75	1.63	0.84	12





# MAXIMIZER™

The new Maximizer™ cleaning tools from Rubbermaid Commercial Products help workers save time by reducing steps in a task, reducing the time of a step and reducing user effort. Engineered to last and designed to perform in a variety of common spaces, Maximizer™ cleaning tools deliver fast, consistent results shift after shift.

## Features and Benefits:

- Extendable handle with 7 positions, adjusting up to 60" length.
- Handle can be shortened for efficient storage between uses
- Quick Change connection is compatible with all Maximizer™ cleaning tool attachments

# QUICK CHANGE EXTENSION HANDLE

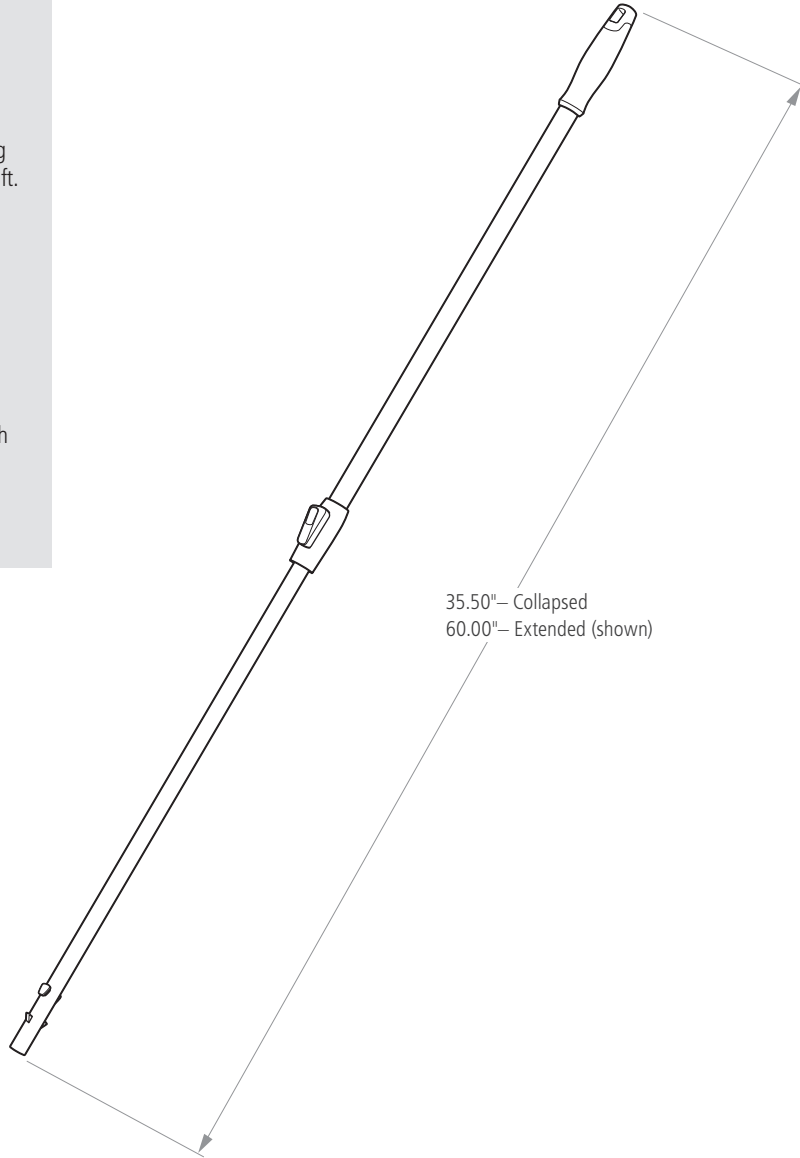

### Unit Packaged Dimensions

SKU #	DESCRIPTION	COLOR	LENGTH IN	WIDTH IN	HEIGHT IN	WEIGHT LB	PACK SIZE
2018789	MAXIMIZER™ QUICK CHANGE EXTENSION HANDLE	YELLOW	35.50	1.75	1.63	0.84	12







# MAXIMIZER™

The new Maximizer™ cleaning tools from Rubbermaid Commercial Products help workers save time by reducing steps in a task, reducing the time of a step and reducing user effort. Engineered to last and designed to perform in a variety of common spaces, Maximizer™ cleaning tools deliver fast, consistent results shift after shift.

## Features and Benefits:

- Kit includes the following:
  - Quick Change Extension Handle
  - Quick Change Scrub Brush
  - Quick Change Microfiber Frame
  - Quick Change Duster
- Attachments easily connect to the Maximizer™ Quick Change Handle
- Attachments store easily in Maximizer™ storage tray

# QUICK CHANGE CLEANING KIT

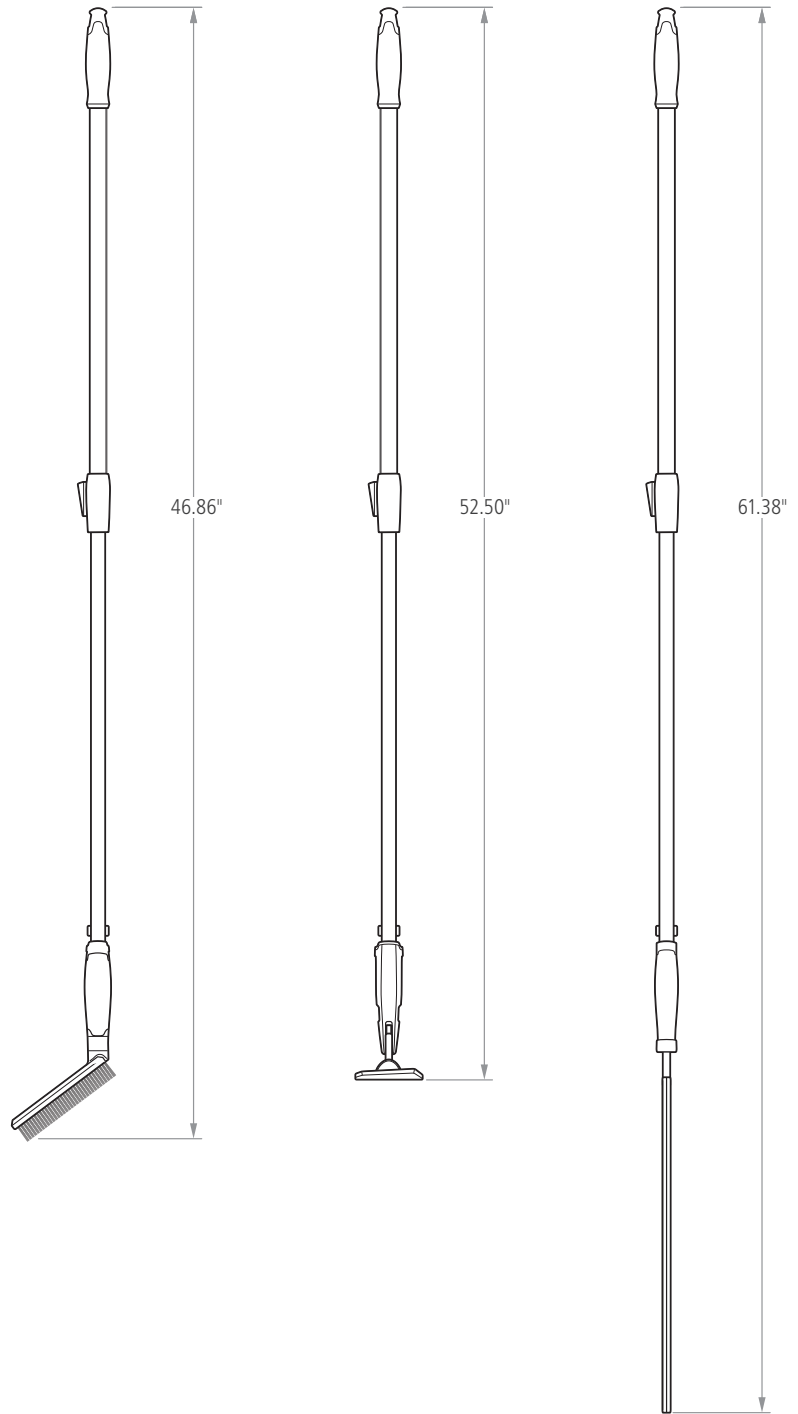

Unit Packaged Dimensions

SKU #	DESCRIPTION	COLOR	LENGTH IN	WIDTH IN	HEIGHT IN	WEIGHT LB	PACK SIZE
2018805	MAXIMIZER™ QUICK CHANGE CLEANING KIT	BLACK	37.00	7.75	3.19	2.21	1





# MAXIMIZER™

The new Maximizer™ cleaning tools from Rubbermaid Commercial Products help workers save time by reducing steps in a task, reducing the time of a step and reducing user effort. Engineered to last and designed to perform in a variety of common spaces, Maximizer™ cleaning tools deliver fast, consistent results shift after shift.

## Features and Benefits:

- EZ Access Scraper connects to handle for quick cleanup of stuck-on debris
- Scraper features a stainless steel blade for durability and superior wear resistance
- Lightweight, quick change handle for easy tool attachment
- Molded grip for comfort
- 24" Dust Mop Frame accepts the 24" Maximizer™ Dust Mop Pad (sold separately)
- 36" Dust Mop Frame accepts the 36" Maximizer™ Dust Mop Pad (sold separately)

## Available Sizes:

- 24"
- 36"

# DUST FRAME, HANDLE, EZ ACCESS SCRAPER

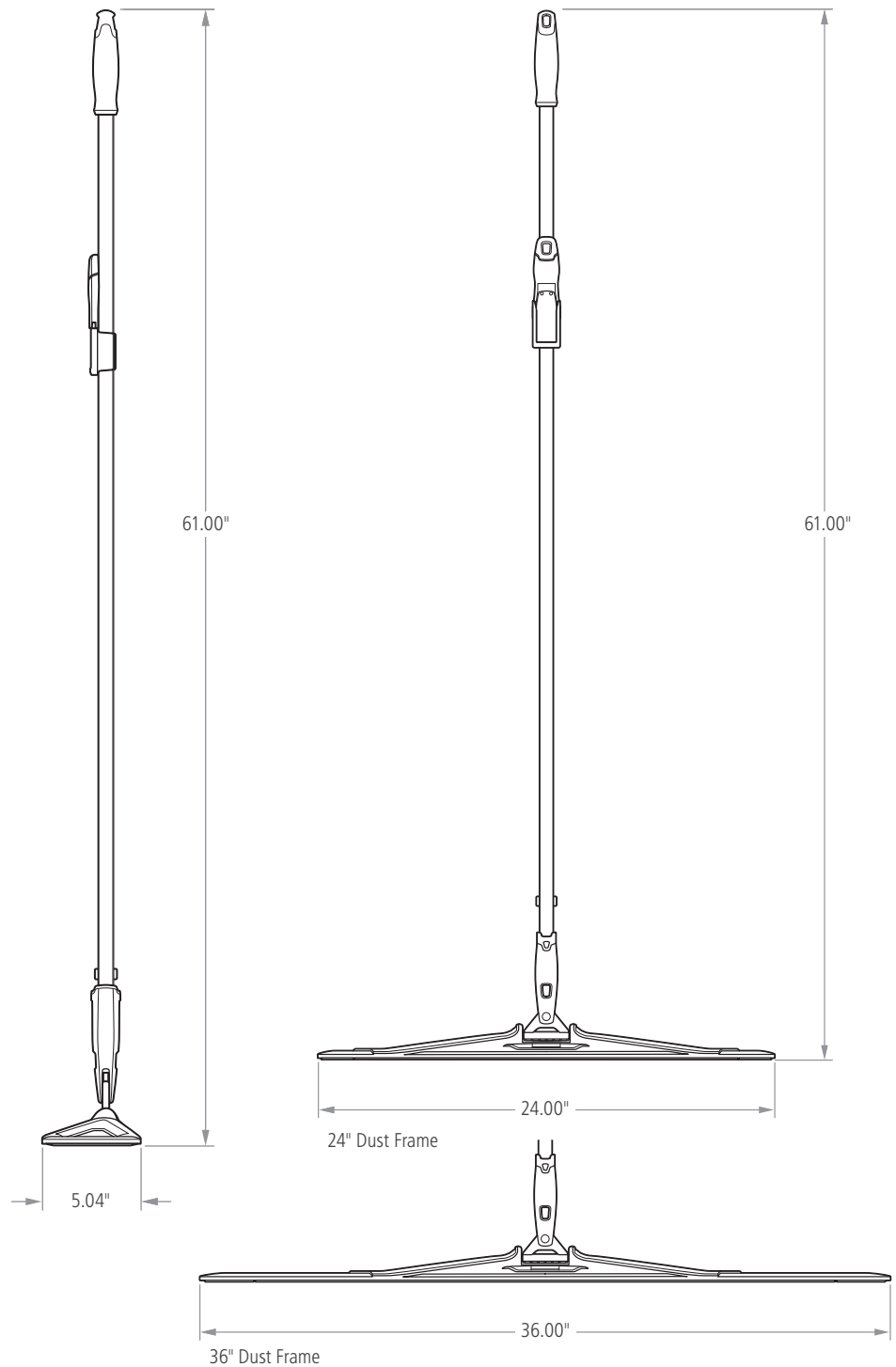

Unit Packaged Dimensions

SKU #	DESCRIPTION	COLOR	LENGTH IN	WIDTH IN	HEIGHT IN	WEIGHT LB	PACK SIZE
2018808	MAXIMIZER™ DUST FRM, HNDL, SCRAPER – 24"	BLACK	57.00	5.50	1.75	1.85	6
2018809	MAXIMIZER™ DUST FRM, HNDL, SCRAPER – 36"	BLACK	57.00	5.50	1.75	2.60	6

