

VMax™ Hand Dryer

 High-Speed Vertical Hand Dryer



WORLD DRYER



- Fast dry time
- Wide hand drying cavity opening
- Hygienic HEPA filter and odor neutralizing system
- Intelligent maintenance system
- ADA Compliant surface mounted



IP33



VMax™ Hand Dryer

High-Speed Vertical Hand Dryer

VMax™ is a 'hands in' vertical style high speed hand dryer featuring a HEPA filter system, a wider hand drying cavity opening and antimicrobial technology. The dedicated water collection reservoir eliminates water from collecting on the floor resulting in reduced maintenance. The quiet operation is ideal for sound sensitive areas.

Fast - 10 - 12 second dry time, 3X faster than the traditional hand dryers

Hygienic - 25% wider hand drying cavity opening • HEPA filter system with odor neutralizing tablet • Incorporates antimicrobial technology inhibiting the growth of bacteria, mold, and fungus extending the hand dryer's service life

Intelligent Maintenance System - LED display indicates when to empty water tray and change HEPA filter for easy maintenance

ADA Compliant - Surface-mounted unit meets ADA accessibility standards

Quiet Operation - Low sound level is ideal for sound sensitive areas

Easy Installation - Simple mounting bracket allows for quick installation



Specifications

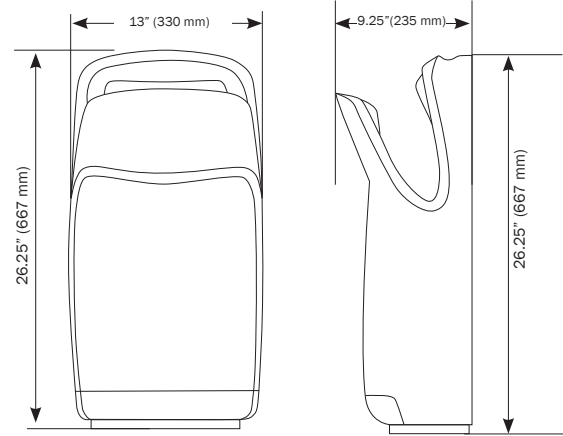

Electrical Specifications

	110-120 V
Amps	10 Amps
Watts	1200 Watts
Hz	60 Hz



110-120 V	Cover Finish / Kit	Cover Material	Unit Weight	Shipping Weight	Unit Size (HxWxD) inch/mm	Shipping Size (HxWxD) inch/mm
# V-639A	Silver	High Impact ABS	19.5 lbs / 8.9 kgs	25 lbs / 11.3 kgs	13" x 26.25" x 9.25" 330 x 667 x 235	16" x 28.5" x 12" 406 x 724 x 305
# 93-10165	HEPA Filter with Odor Neutralizing Tablet (1 pk)		0.17 lb / 0.08 kg	0.2 lb / 0.09 kg	6.29" x 1.57" x 2.44" 160 x 40 x 62	6.29" x 1.57" x 2.44" 160 x 40 x 62
# 93-10165-4pk	HEPA Filter with Odor Neutralizing Tablet (4 pk)		0.67 lb / 0.31 kg	0.82 lb / 0.37 kg	6.29" x 1.57" x 2.44" 160 x 40 x 62	6.5" x 6.6" x 2.75" 165 x 168 x 70



5700 McDermott Drive, Berkeley, IL 60163
 Tel: (800) 323-0701, (708) 449-6950
 Fax: (708) 449-6958
 www.worlddryer.com

92-MT078 Rev00

Distributor

VMax™ is a 'hands in' vertical style high speed hand dryer featuring a HEPA filter system, wider hand drying cavity opening and antimicrobial technology. Dedicated water collection reservoir eliminates water from collecting on the floor resulting in reduced maintenance. Quiet operation is ideal for sound sensitive areas.

Product Features and Benefits

- 10 - 12 second dry time
- 25% greater hand drying cavity opening provides comfortable dry without touching sides of hand dryer
- HEPA filter with odor neutralizing tablet reduces contaminants in the air when hand drying
- Water collection reservoir eliminates water from collecting on the floor resulting in reduced maintenance
- LED display indicates when to empty water tray and change HEPA filter for easy maintenance
- Quiet operation ideal for sound sensitive areas
- ADA compliant
- Simple mounting bracket for easy installation
- Incorporates antimicrobial technology inhibiting the growth of bacteria, mold and fungus extending the dryer's service life
- Automatic operation promotes hand hygiene
- Durable and vandal resistant
- IP33 ingress protection against water



Architecture & Engineering Specifications

VMax hand dryer supplied by World Dryer Corporation shall have a power consumption of 1200 watts powered by a thermally-protected universal brush type motor operating at 35,000 RPM. Hand dryer shall nominally deliver 85 CFM air flow at a velocity of 335 MPH (29, 480 LFM). Dryer shall be activated by an automatic infrared sensor with a 20 second vandal shut-off. Dryer exterior shall be constructed of high impact ABS polymer incorporating antimicrobial technology to inhibit the growth of bacteria, mold and fungus extending the dryer's service life. Dryer will incorporate a drain inside the drying cavity with a water collection tray*, replaceable HEPA filter¹ and odor neutralizing tablet² and LED display for identifying operation and servicing requirements. Hand dryers shall be certified to Underwriters Laboratories standards for safety.

Electrical specifications:

	110-120 V
Amps	10
Watts	1200
Hz	60 Hz

* The water collection tray will fill with water with hand dryer use. The LED Display will indicate when the water collection tray is full and needs emptying. High washroom traffic may require more frequent emptying of the water collection tray.

^{1,2} This hand dryer is equipped with a replaceable cartridge containing a HEPA filter and an odor neutralizing tablet. The LED display panel will indicate when the HEPA filter requires replacement. High washroom traffic may require more frequent replacement of the HEPA filter.

Cover Material	Cover Finish / Kit	110-120 V	Unit Weight	Shipping Weight	Unit Size (HxWxD) inch/mm	Shipping Size (HxWxD) inch/mm
High Impact ABS	Silver	# V-639A	19.5 lbs / 8.9 kgs	25 lbs / 11.3 kgs	13" x 26.25" x 9.25" 330 x 667 x 235	16" x 28.5" x 12" 406 x 724 x 305
HEPA Filter with Odor Neutralizing Tablet (1 pk)		# 93-10165	0.17 lb / 0.08 kg	0.2 lb / 0.09 kg	6.29" x 1.57" x 2.44" 160 x 40 x 62	6.29" x 1.57" x 2.44" 160 x 40 x 62
HEPA Filter with Odor Neutralizing Tablet (4 pk)		# 93-10165-4pk	0.67 lb / 0.31 kg	0.82 lb / 0.37 kg	6.29" x 1.57" x 2.44" 160 x 40 x 62	6.5" x 6.6" x 2.75" 165 x 168 x 70

Specifications :

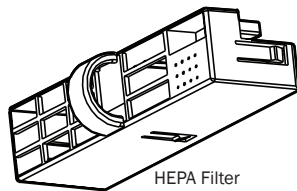
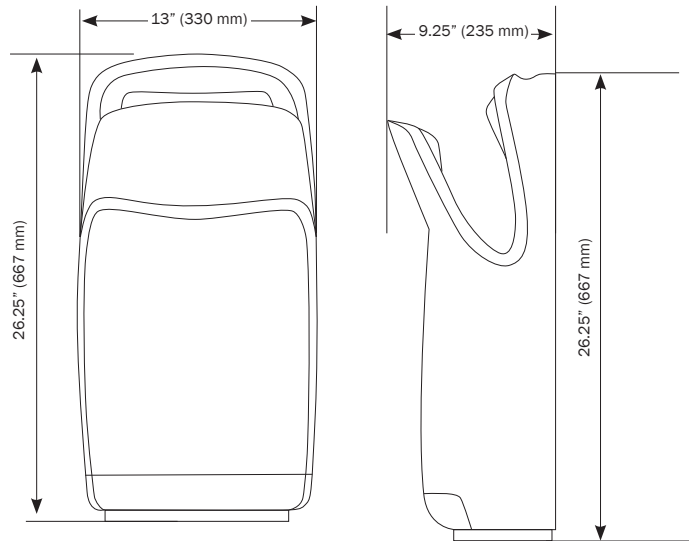

HEPA Filter

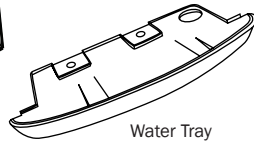

Water Tray

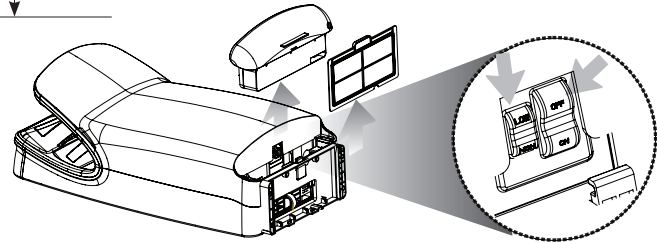

LED Display :

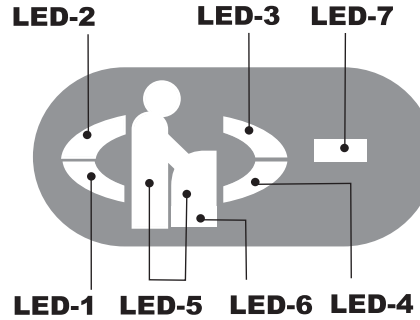

LED Display

The LED display provides information about the operation and servicing needs of the hand dryer.

- LED's 1 through 4 flash Green when dryer is in operation.
- LED 5 is solid Green when dryer is in standby mode; solid Blue when dryer is in operation.
- LED 6 is unlit during normal operation; flashing Red when HEPA filter requires replacement.
- LED 7 is unlit during normal operation; solid Blue when water collection tank needs emptying.

How to Use

1. The hand dryer will start automatically when hands are inserted.
2. Slowly move your hands up and down through the air stream for 10 - 12 seconds.
3. The hand dryer will stop automatically after hands are removed.

Installation Guide

1. Use the mounting template provided to mark the locations for the (4) wall mounting anchors to attach the wall mounting bracket to the wall.
2. To use the hollow wall anchors included with the wall mounting kit, pre-drill the wall in the marked locations using a 5/16" (8mm) drill, insert the plastic anchors and tap flush to the wall.
3. Complete the attachment of the wall mounting bracket to the wall with the (4) mounting anchors using a No. 25 torx screwdriver.
4. Hang the hand dryer on the bracket. Remove water collection tray from bottom of dryer, and complete the attachment of the dryer with the 4th anchor.

Certifications



Intertek

IP33



Warranty



5 year limited warranty



5700 McDermott Drive
Berkeley, IL 60163 U.S.A.
800-323-0701
www.worlddryer.com



Sèche-mains VMax^{MC}

 Sèche-mains vertical haute vitesse



WORLD DRYER



- Temps de séchage ultra-rapide
- Large bouche de séchage
- Filtre HEPA hygiénique et dispositif anti-odeur
- Système d'entretien intelligent
- Sèche-mains en applique conforme aux normes ADA



IP33



Sèche-mains VMax^{MC}

Sèche-mains vertical haute vitesse

Le VMax^{MC} est un sèche-mains haute vitesse vertical, activé par insertion des mains. Il se démarque par son filtre HEPA, sa bouche de séchage plus large et sa technologie antimicrobienne. Un bac spécial récupère l'eau chassée, ce qui élimine les flaques et réduit d'autant l'entretien. Le fonctionnement silencieux est idéal pour les endroits sensibles au bruit.

Ultra-rapide - Temps de séchage de 10 à 12 secondes, 3 fois plus rapide que les sèche-mains ordinaires

Hygiénique - bouche de séchage 25 % plus large • Filtre HEPA avec tablette anti-odeur • Intègre une technologie antimicrobienne qui empêche la croissance de bactéries, de moisissures et de champignons prolongeant par conséquent la durée de service utile du sèche-mains

Système d'entretien intelligent - L'affichage à DEL facilite l'entretien, en signalant quand vider le bac et remplacer le filtre HEPA

Conformité ADA - L'appareil en applique est conforme aux normes d'accessibilité ADA

Fonctionnement silencieux - Faible niveau sonore, idéal pour les endroits sensibles au bruit

Facile d'installation - Support de montage simple qui permet une installation rapide

L'affichage à DEL intelligent indique quand :

- vider le bac d'eau
- remplacer le filtre HEPA

Capot imprégné d'un traitement antimicrobien

Large bouche de séchage



Bac de récupération d'eau



Filtre hygiénique HEPA avec tablette anti-odeur

Fiche technique

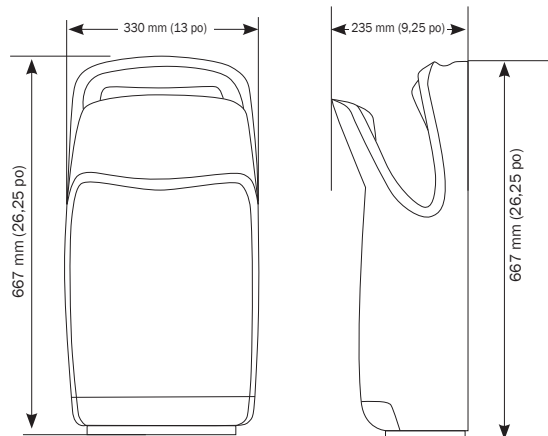

Caractéristiques électriques

	110-120 V
Ampères	10 A
Watts	1 200 W
Hz	60 Hz



Gris argenté

110-120 V	Fini du boîtier/ensemble	Matière du boîtier	Poids unitaire	Poids à l'expédition	Dimensions de l'unité (HxLxP) po/mm	Dimensions à l'expédition (HxLxP) po/mm
N° V-639A	Gris argenté	ABS hautement résistant	19,5 lb/8,9 kg	25 lb/11,3 kg	13 po x 26,25 po x 9,25 po 330 x 667 x 235	16 po x 28,5 po x 12 po 406 x 724 x 305
N° 93-10165	Filtre HEPA avec tablette anti-odeur (paquet de 1)		0,17 lb/0,08 kg	0,2 lb/0,09 kg	6,29 po x 1,57 po x 2,44 po 160 x 40 x 62	6,29 po x 1,57 po x 2,44 po 160 x 40 x 62
N° 93-10165-Paquet de 4	Filtre HEPA avec tablette anti-odeur (paquet de 4)		0,67 lb/0,31 kg	0,82 lb/0,37 kg	6,29 po x 1,57 po x 2,44 po 160 x 40 x 62	6,5 po x 6,6 po x 2,75 po 165 x 168 x 70

 **WORLD DRYER**



5700 McDermott Drive, Berkeley, IL 60163
Tél. : (800) 323-0701, (708) 449-6950
Télééc. : (708) 449-6958
www.worlddryer.com

92-MT078 Rev00

Distributeur