

WAVEBRAKE® EXECUTIVE SERIES™ BUCKET AND WRINGER

With features that surpass traditional mop buckets, the new generation WaveBrake® helps to clean floors with less effort to get the job done safer, without sacrificing quality and durability.

Features and Benefits:

- Up to 80% less splashing.* Patented WaveBrake® baffles result in less splashing while mopping and maneuvering, helping to create a safer environment for patrons and staff
- WaveBrake® wringers are guaranteed to last 5 years or 200,000 cycles
- Integrated handles and sink ledge make it easy to lift and empty the mop bucket with less strain
- Pour spout helps prevent water from spilling on to floors while emptying dirty water
- Integrated wringer-guides ensure a secure connection to mop bucket, providing stability while wringing and maneuvering
- Non-marking casters will not scuff floors to keep them looking their best
- Executive Series™ WaveBrake® incorporates quiet casters to clean discreetly
- Executive Series™ WaveBrake® bucket includes dirty water bucket that nests below the wringer to keep dirty water separate from clean

*versus competitive 35Qt U.S. single compartment mop bucket and wringer, not including divider bucket and accessories.

Material Composition:

- Bucket and wringer are made with structural web-molded plastic
- Wringer and bail handles are made with steel
- Back of bucket red handle is polypropylene
- Dirty Water Bucket is high-pressure injection-molded plastic

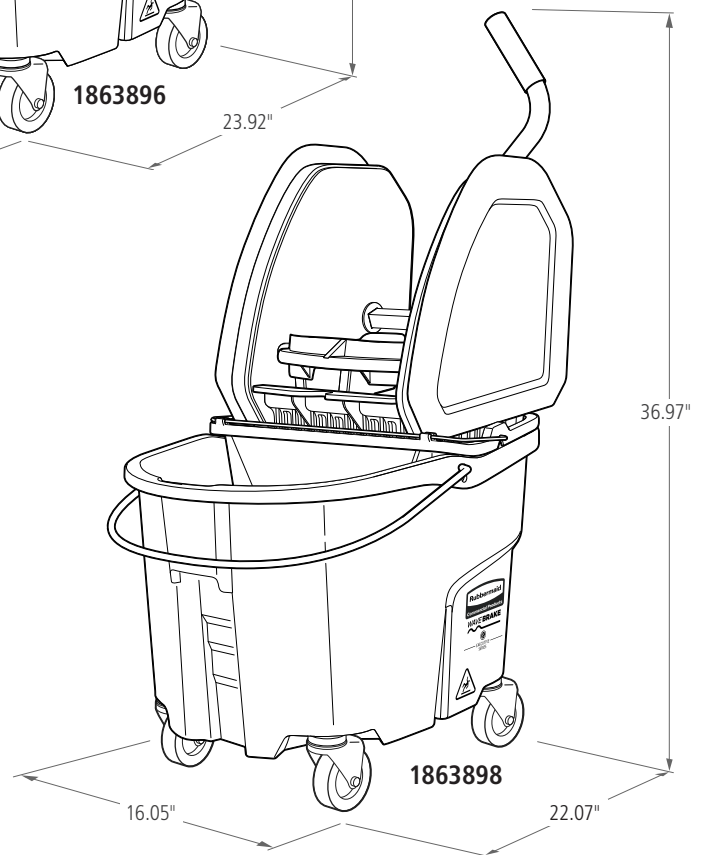
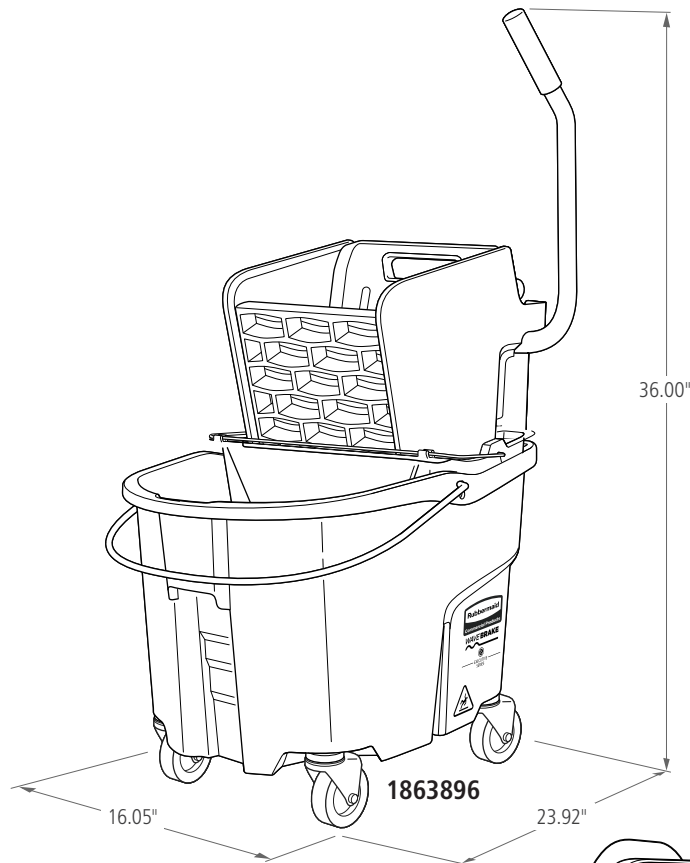

Unit Packaged Dimensions

SKU #	DESCRIPTION	COLOR	CAPACITY	LENGTH	WIDTH	HEIGHT	WEIGHT	CASE QTY
			QT	IN	IN	IN	LB	
1863896	35-QT WAVEBRAKE® SIDE-PRESS BUCKET AND WRINGER, EXECUTIVE SERIES	BLACK	35	23.92	16.05	36.00	19.60	1
1863898	35-QT WAVEBRAKE® DOWN-PRESS BUCKET AND WRINGER, EXECUTIVE SERIES	BLACK	35	22.07	16.05	36.97	19.15	1

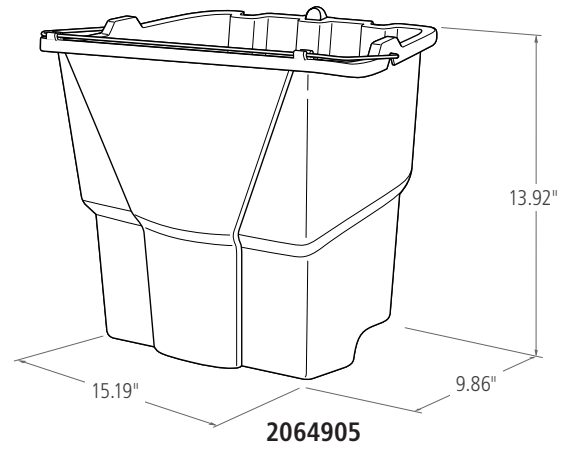
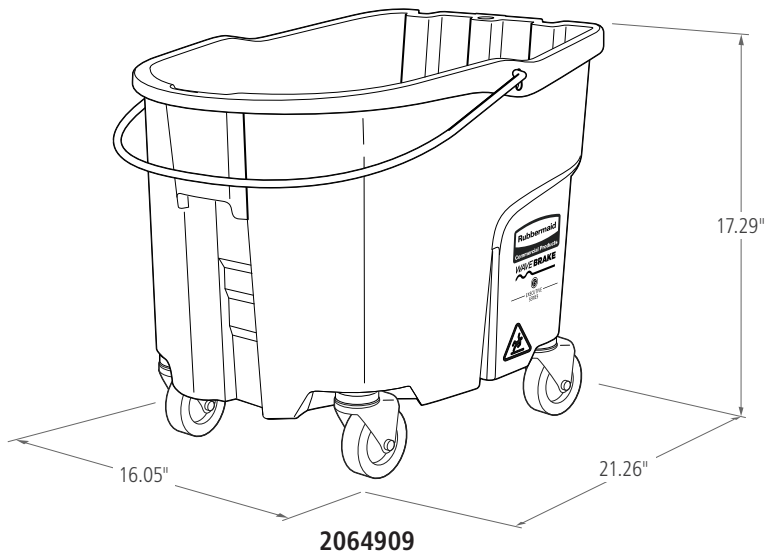
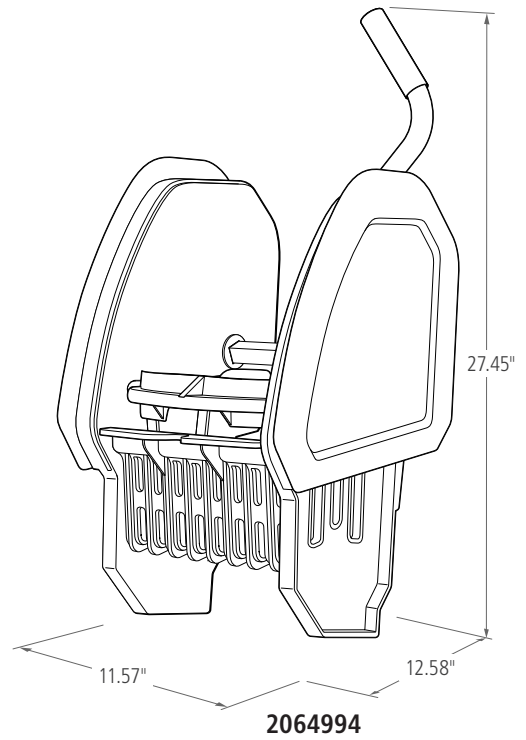
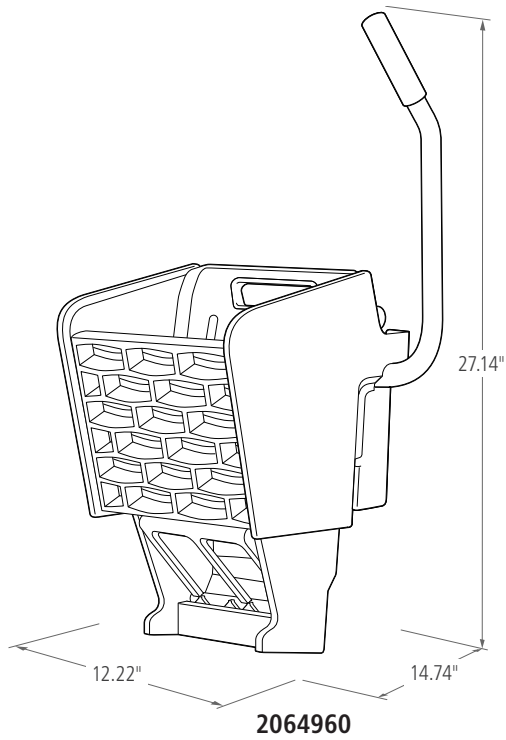

Replacement Parts

SKU #	DESCRIPTION	COLOR	CAPACITY	LENGTH	WIDTH	HEIGHT	WEIGHT	CASE QTY
				QT	IN	IN		
2064960	WAVEBRAKE® SIDE-PRESS WRINGER, EXECUTIVE SERIES	BLACK	N/A	14.74	12.22	27.14	9.95	2
2064994	WAVEBRAKE® DOWN-PRESS WRINGER, EXECUTIVE SERIES	BLACK	N/A	12.58	11.57	27.45	9.50	2
2064909	35-QT WAVEBRAKE® BUCKET AND CASTERS, EXECUTIVE SERIES	BLACK	35	21.26	16.05	17.29	9.65	4
2064905	35-QT WAVEBRAKE® DIRTY WATER BUCKET	GRAY	35	9.86	15.19	13.92	2.25	6

