

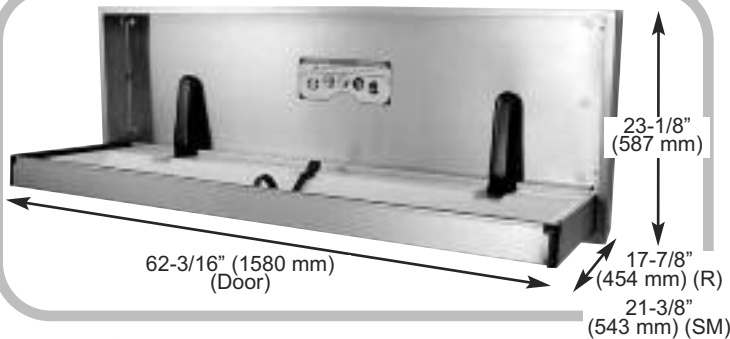

## Model 100-SSE-R, 100-SSE-SM Special Needs Stainless Steel Diaper Changing Station

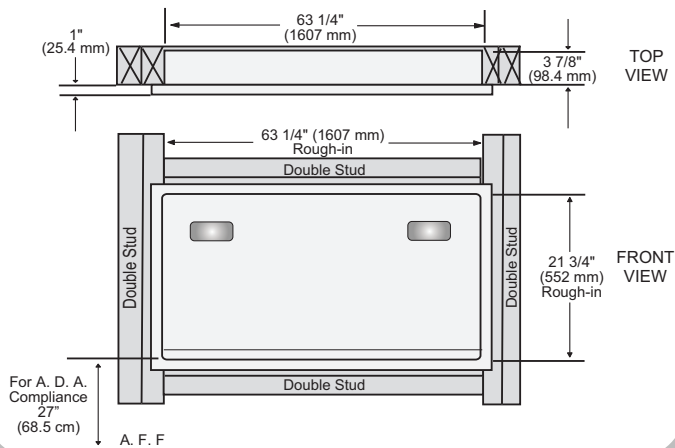

### Recommended Blocking Recessed Mount



### Recommended Blocking Surface Mount

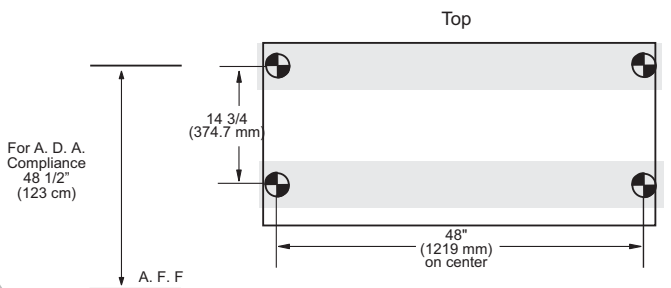

### Installation Information

- 3.88 inches (98 mm) recessed into wall, 1 inch (25 mm) protrusion from wall. Unit projects 4 inches (100 mm) when surface mounted.
- Rough-in opening 63.25 inches (1607 mm) wide x 21.75 inches (552 mm) high. Shim as required for tight fit on all 4 sides. For recess mount, use side mounting holes.
- Open unit project from wall 17.875 inches (454 mm) when recessed and 21.375 inches (543 mm) when surface mounted.
- 3.5 inches (89 mm), 18 gauge metal studs minimum. Line studs with trimmed 2 x 4's.

- Full body 16 gauge, 304 brushed stainless steel.
- Polystyrene replaceable tray liner.
- Rated to support a static load of 400 pounds (181 kg).
- Adult or physically challenged changing station ideal for schools, nursing homes and hospitals.
- Safety belt with cam-buckle is adjustable with one hand.
- Full stainless steel frame and hinges provide maximum durability.
- Easy to read ANSI compliant labels (ANSI Z535.3 and ANSI Z535.4), utilizing universal safety symbols.
- Pneumatic gas shock mechanisms to ensure smooth, safe open and close motions.
- Includes universal changing station door sign.
- Universal changing station plaque on front of unit.
- Surface mount requires additional flange. Specify model 100-SSE-SM.
- Extended length of 62 inches (1575 mm).
- Limited Warranty: This product is warranted against manufacturing defects for a period of 5 years.

### Short Specifications

Full 304 brushed stainless steel exterior with vacuum formed polystyrene changing surface.

1. A.D.A Compliant attached buckle.
2. Acceptable product: Foundations Worldwide, Inc.; Model 100-SSE-R (Horizontal Recessed Mount) & 100-SSE-SM (Horizontal Surface Mount).
3. Characteristics:
  - a. Entire body 16 gauge, 304 brushed stainless steel, seamless welds.
  - b. Provide Foundations Worldwide, Inc. SS-Flange in order to surface mount unit.
  - c. Provide Foundations Worldwide, Inc. 200-SSLD; stainless steel liner dispenser.
4. Equipped with pneumatic cylinders.
5. Smooth nylon safety belt is easily cleaned.
6. 400 lb. (181 kg) load rating exceeds ASTM F2285 requirements for weight bearing changing stations.
7. **A.D.A. Compliance:**
  - 4.4.1 Maximum Protruding Objects
  - 4.2.5 Forward Reach
  - 4.2.6 Parallel Approach
  - 4.27.4 Operation  
Compliant when properly installed.
8. ANSI compliant safety labels.
9. CPSIA compliant to applicable sections.

