

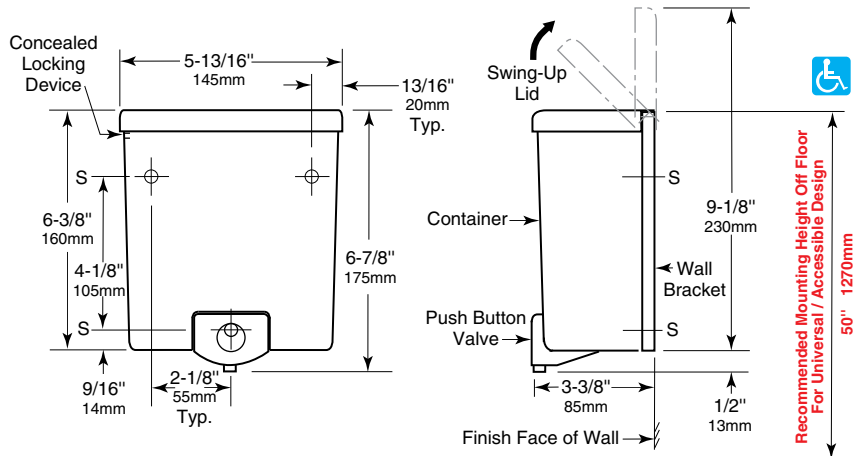

SOAP DISPENSER FOR LIQUID AND LOTION SOAPS, AND DETERGENTS

B-40



MATERIAL:

Valve — Grey, high-impact-resistant ABS push button and spout. Soap head-holding mushroom valve. Stainless steel spring. U-packing seal and duckbill.

Wall Bracket — Grey, high-impact-resistant ABS. Equipped with a concealed locking device to secure the lid and a removable plastic key to disengage locking device.

Container — Black, translucent ABS. Capacity: 40-fl oz (1.2-L).

Lid — Grey, high-impact-resistant ABS.

OPERATION:

Corrosion-resistant valve dispenses commercially marketed all-purpose hand soaps. Valve is operable with one hand, without tight grasping, pinching, or twisting of the wrist, and with less than 5 pounds of force (22.2 N) to comply with accessible design (including ADAAG in U.S.A.). Large-capacity, translucent container provides visible soap level. To fill container, use the plastic key provided or any small pointed object to push in the concealed locking device located at upper left side of wall bracket; lid will automatically pop forward. Lid swings up to top fill only after lock is disengaged. After filling, swing lid down and push it toward the wall; a click sound confirms lid is locked. Soap container is removable for maintenance or replacement by opening the lid, pushing back on the container stop spring tab and sliding the container up off the wall bracket. Replace the lid before mounting the container onto the wall bracket.

INSTALLATION:

Remove plastic key from wall bracket. Provide (3) #10 x 1-1/2" (M5 x 38mm) mounting screws to mount the wall bracket on wall at points indicated by an S. For plaster or dry wall construction, provide concealed backing to comply with local building codes, then secure unit with screws. For other wall surfaces, provide fiber plugs or expansion shields with screws, or provide 1/8" (3mm) toggle bolts or expansion bolts. For mirrors or glass surfaces, use pressure-sensitive tape strips furnished by manufacturer: Apply tape to back of wall bracket within outlined areas; press wall bracket onto glass surface; then allow the tape to set 24 hours before mounting the container and filling with soap. Hold lid upright in-line with wall bracket and slide its two pivot points into upper left and right slots of wall bracket; a click sound will be heard when lid is properly in place. With lid in the upright (open) position, slide container down into the wall bracket's V-shaped groove. Swing lid down and push it toward the wall; a click sound confirms lid is locked.

Note: Provide 4" (100mm) minimum clearance from lid to underside of any horizontal projection for top filling and 5" (125mm) minimum clearance to the left of unit for disengaging the concealed locking device. Push buttons should be located 44" (1120mm) maximum above the finish floor.

SPECIFICATION:

Soap dispenser shall have grey, high-impact-resistant ABS wall bracket, lid, push button, and spout. Bracket shall be equipped with a locking device to secure lid, container, and a removable plastic key to disengage locking device. Vandal-resistant lid shall pivot up for top filling only after lock is disengaged. Corrosion-resistant valve shall have soap head-holding mushroom valve, stainless steel spring, U-packing seal, and duckbill; and shall dispense commercially marketed all purpose hand soaps. Valve shall be operable with one hand and with less than 5 pounds of force (22.2 N) to comply with accessible design (including ADAAG in U.S.A.). Container shall be black, translucent ABS with a capacity of 40-fl oz (1.2-L), be retained to the wall bracket by a sliding latch and a container stop spring tab and shall be removable for maintenance or replacement.

Soap Dispenser shall be Model B-40 of Bobrick Washroom Equipment, Inc., Clifton Park, New York; Jackson, Tennessee; Los Angeles, California; Bobrick Washroom Equipment Company, Scarborough, Ontario; Bobrick Washroom Equipment Pty. Ltd., Australia; and Bobrick Washroom Equipment Limited, United Kingdom.