

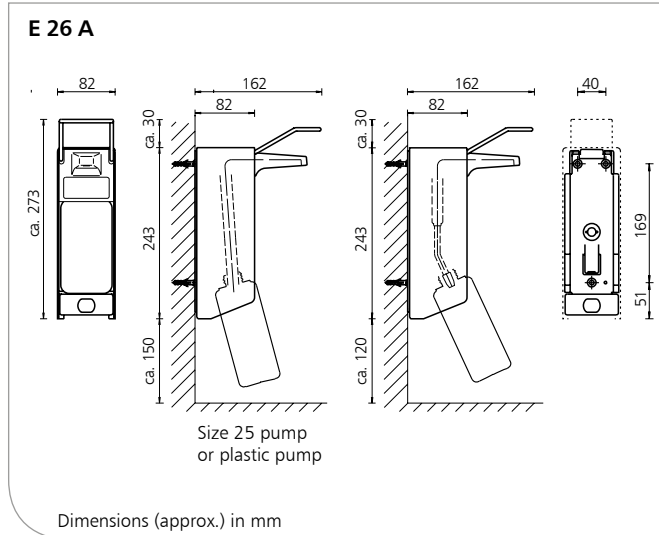

## E 26 A

Soap-/disinfectant dispenser for disposable bottles as well as refillable containers, aluminium housing, short operating lever, 500 ml



### Product characteristics

- ▶ Dispenser for liquid soaps, detergents, alcoholic hand disinfectants, lotions, etc.
- ▶ For 500 ml disposable bottles as well as refillable containers
- ▶ With replaceable pump
- ▶ Incl. mounting kit for three-point wall mounting

### Interesting information

References:

- ▶ Clinics, doctors' practices, health and care facilities, laboratories, rescue stations, commercial kitchens, foodstuffs industry

Application examples:

- ▶ Particularly well suited to areas where hand hygiene is critical and in medical and food processing area

### Technical data

Housing:

Aluminium, anodised matt silver

Dosing pump:

Size 25 pump, stainless steel, straight suction tube, size 24 pump, stainless steel, cranked suction tube, K-pump, universal plastic pump, F-pump, plastic foam soap pump, KSP-pump, plastic disinfectant spray pump, 25+24 pumps autoclavable up to 121°C, 2 bar, plastic pumps not autoclavable

Dispensing quantity:

K-pump, KSP-pump ca. 1.5 ml/stroke, reducible in 3 steps, size 24, size 25 pumps adjustable to ca. 0.7 ml/1.0 ml/1.5 ml (depending on the viscosity of the filling material)

Operating lever:

Stainless steel

Wall plate:

Standard ingo-man® plastic wall plate

Wall mounting:

Wall mounting with 3 screws and wall plugs

Cleaning:

Dispenser and standard pump dishwasher-safe and autoclavable up to 121° C, 2 bar

Description for tender - see overleaf

E 26 A/0320/1.3



Subject to technical modifications.  
Tests are required before new filling materials are used!



Ophardt Hygiene-Technik GmbH + Co. KG

Lindenau 27 | 47661 Issum | Germany

Tel.: +49 (0) 28 35 18-10 | Fax +49 (0) 28 35 18-77

planer@ophardt.com | www.ophardt.com

# E 26 A

Soap-/disinfectant dispenser for disposable bottles as well as refillable containers, aluminium housing, short operating lever, 500 ml

## Description for tender

... Pcs. **ingo-man® classic E 26 A/24**  
**Art. No. 1220000**  
Soap-/disinfectant dispenser, 500 ml, suitable for standard disposable bottles as well as refillable containers, matt silver anodised aluminium housing, short stainless steel operating lever, with identification clip, incl. empty bottle, replaceable size 24 stainless steel pump, pump can be quickly and simply removed from the rear of the dispenser for cleaning without mounting tools - can be put back into service in reverse order with "push and click" system, autoclavable and dishwasher-safe  
Dimensions: W 82 x H 273 x D 162 mm

... Pcs. **ingo-man® classic E 26 A/25**  
**Art. No. 1220100**  
Soap-/disinfectant dispenser, 500 ml, suitable for standard disposable bottles as well as refillable containers, matt silver anodised aluminium housing, short stainless steel operating lever, with identification clip, incl. empty bottle, replaceable size 25 stainless steel pump, pump can be quickly and simply removed from the rear of the dispenser for cleaning without mounting tools - can be put back into service in reverse order with "push and click" system, autoclavable and dishwasher-safe  
Dimensions: W 82 x H 273 x D 162 mm

... Pcs. **ingo-man® classic E 26 A/K**  
**Art. No. 836900**  
Soap-/disinfectant dispenser, 500 ml, suitable for standard disposable bottles as well as refillable containers, matt silver anodised aluminium housing, short stainless steel operating lever, with identification clip, incl. empty bottle, replaceable plastic pump, pump can be quickly and simply removed from the rear of the dispenser for cleaning without mounting tools - can be put back into service in reverse order with "push and click" system, autoclavable and dishwasher-safe  
Dimensions: W 82 x H 273 x D 162 mm

... Pcs. **ingo-man® classic E 26 A/KSP**  
**Art. No. 1412576**  
Disinfectant dispenser, 500 ml, suitable for standard disposable bottles as well as refillable containers, matt silver anodised aluminium housing, short stainless steel operating lever, with identification clip, incl. empty bottle, replaceable plastic disinfectant spray pump, pump can be quickly and simply removed from the rear of the dispenser for cleaning without mounting tools - can be put back into service in reverse order with "push and click" system, autoclavable and dishwasher-safe  
Dimensions: W 82 x H 273 x D 162 mm

... Pcs. **ingo-man® classic E 26 A/F**  
**Art. No. 1415729**  
Foam soap dispenser, 500 ml, suitable for standard disposable bottles as well as refillable containers, matt silver anodised aluminium housing, short stainless steel operating lever, with identification clip, incl. empty bottle, replaceable plastic foam soap pump, pump can be quickly and simply removed from the rear of the dispenser for cleaning without mounting tools - can be put back into service in reverse order with "push and click" system, autoclavable and dishwasher-safe  
Dimensions: W 82 x H 273 x D 162 mm

Product: **ingo-man® classic**  
Manufacturer: OPHARDT HYGIENE-TECHNIK GmbH + Co. KG