

## IMP E A - IMP T A

Soap-/disinfectant dispenser for disposable bottles as well as refillable containers and hygiene packages, aluminium housing, short operating lever, 500 ml or 1000 ml

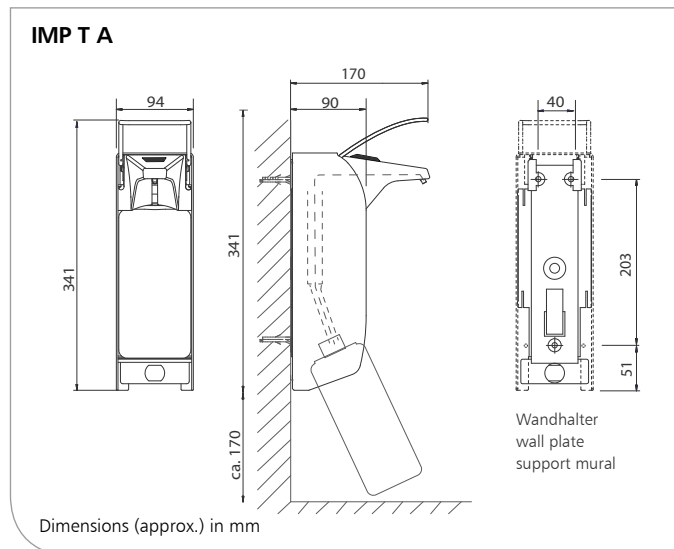
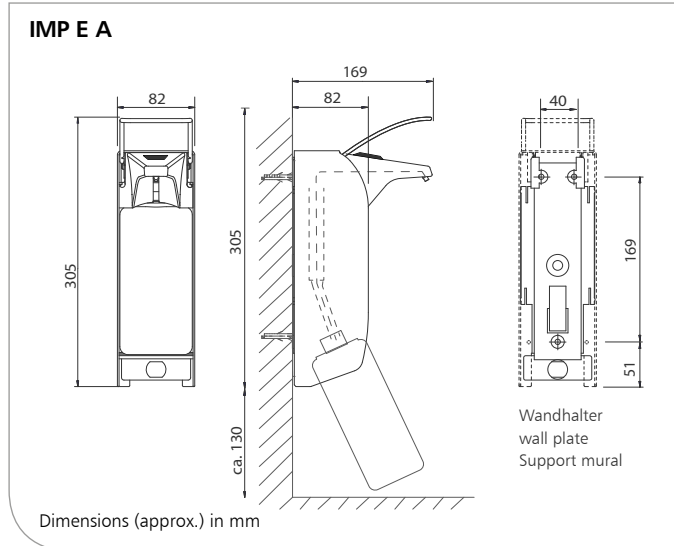

### Product characteristics

- ▶ Dispenser for liquid soaps without grit, alcoholic hand disinfectants, lotion, massage oil, etc.
- ▶ For 500 ml or 1000 ml disposable bottles as well as refillable containers and hygiene packages
- ▶ For different pump types
- ▶ Pivoting face shield for simple pump replacement from the front without having to remove the dispenser from the wall
- ▶ Incl. mounting kit for three-point wall mounting
- ▶ Smart upgrade module for retrofitting (for 500 ml version): Compatible with ingo-man® SmartNose for fully automatic and continuous electronic hand hygiene monitoring

### Interesting information

References: ▶ Clinics, doctors' practices, health and care facilities, laboratories, rescue stations, commercial kitchens, foodstuffs industry, commercial and industrial operations

Application examples: ▶ Particularly well suited to areas where hand hygiene is critical and in medical and food processing areas

### Technical data

Housing: Aluminium, anodised matt silver  
 Dosing pump: DHP disposable hygiene pump, made with recyclable plastic (standard pump, for other pumps see overleaf)  
 Dispensing quantity: 1.5 ml/stroke (depending on the viscosity of the filling material)  
 Operating lever: Stainless steel  
 Wall plate: Standard ingo-man® plastic wall plate  
 Wall mounting: Wall mounting with 3 screws and wall plugs  
 Cleaning: Dispenser and stainless steel pumps dishwasher-safe and autoclavable up to 134° C, 2 bar

Description for tender - see overleaf

IMP E A - T A/0320/3.0



Subject to technical modifications.  
 Tests are required before new filling materials are used!



Ophardt Hygiene-Technik GmbH + Co. KG

Lindenau 27 | 47661 Issum | Germany

Tel.: +49 (0) 28 35 18-10 | Fax +49 (0) 28 35 18-77

planer@ophardt.com | www.ophardt.com

# IMP E A - IMP T A

Soap-/disinfectant dispenser for disposable bottles as well as refillable containers and hygiene packages, aluminium housing, short operating lever, 500 ml or 1000 ml

## Description for tender

... Stück	<p><b>ingo-man® plus IMP E A/DHP</b> <b>Art.-No. 4402102</b></p> <p>Soap-disinfectant dispenser, 500 ml, suitable for standard disposable bottles, refillable containers and hygiene packages, matt silver anodised aluminium housing, short stainless steel operating lever, with identification clip, autoclavable and dishwasher-safe dispenser, recyclable disposable pump, plastic, easy pump replacement through front removal, retrofittable smart functionality Dimensions: W 82 x H 305 x D 169 mm</p>	... Pcs.	<p><b>ingo-man® plus IMP E A/25</b> <b>Art.-No. 1417548</b></p> <p>Soap-/disinfectant dispenser, 500 ml, suitable for standard disposable bottles, refillable containers and hygiene packages, matt silver anodised aluminium housing, short stainless steel operating lever, with identification clip, incl. empty bottle, replaceable IMP 25 series stainless steel pump, autoclavable and dishwasher-safe, pump can be quickly and simply removed for cleaning through front removal - can be put back into service in reverse order with "push and click" system, retrofittable smart functionality Dimensions: W 82 x H 305 x D 169 mm</p>
... Stück	<p><b>ingo-man® plus IMP T A/DHP</b> <b>Art.-No. 4402107</b></p> <p>Soap-disinfectant dispenser, 1000 ml, suitable for standard disposable bottles, refillable containers and hygiene packages, matt silver anodised aluminium housing, short stainless steel operating lever, with identification clip, autoclavable and dishwasher-safe dispenser, recyclable disposable pump, plastic, easy pump replacement through front removal Dimensions: W 94 x H 341 x D 170 mm</p>	... Pcs.	<p><b>ingo-man® plus IMP T A/25</b> <b>Art.-No. 1417588</b></p> <p>Soap-/disinfectant dispenser, 1000 ml, suitable for standard disposable bottles, refillable containers and hygiene packages, matt silver anodised aluminium housing, short stainless steel operating lever, with identification clip, incl. empty bottle, replaceable IMP 25 series stainless steel pump, pump can be quickly and simply removed for cleaning through front removal - can be put back into service in reverse order with "push and click" system, autoclavable and dishwasher-safe Dimensions: W 94 x H 341 x D 170 mm</p>
... Pcs.	<p><b>ingo-man® plus IMP E A/24</b> <b>Art.-No. 1417021</b></p> <p>Soap-disinfectant dispenser, 500 ml, suitable for standard disposable bottles, refillable containers and hygiene packages, matt silver anodised aluminium housing, short stainless steel operating lever, with identification clip, incl. empty bottle, replaceable IMP 24 series stainless steel pump, pump can be quickly and simply removed for cleaning through front removal - can be put back into service in reverse order with "push and click" system, autoclavable and dishwasher-safe, retrofittable smart functionality Dimensions: W 82 x H 305 x D 169 mm</p>	... Pcs.	<p><b>ingo-man® plus IMP E A/K</b> <b>Art.-No. 1417549</b></p> <p>Soap-/disinfectant dispenser, 500 ml, suitable for standard disposable bottles, refillable containers and hygiene packages, matt silver anodised aluminium housing, short stainless steel operating lever, with identification clip, incl. empty bottle, dishwasher-safe, replaceable plastic pump, pump can be quickly and simply removed for cleaning through front removal - can be put back into service in reverse order with "push and click" system, autoclavable and dishwasher-safe dispenser, retrofittable smart functionality Dimensions: W 82 x H 305 x D 169 mm</p>
... Pcs.	<p><b>ingo-man® plus IMP T A/24</b> <b>Art.-No. 1417022</b></p> <p>Soap-/disinfectant dispenser, 1000 ml, suitable for standard disposable bottles, refillable containers and hygiene packages, matt silver anodised aluminium housing, short stainless steel operating lever, with identification clip, incl. empty bottle, replaceable IMP 24 series stainless steel pump, pump can be quickly and simply removed for cleaning through front removal - can be put back into service in reverse order with "push and click" system, autoclavable and dishwasher-safe Dimensions: W 94 x H 341 x D 170 mm</p>	... Pcs.	<p><b>ingo-man® plus IMP T A/K</b> <b>Art.-No. 1417589</b></p> <p>Soap-/disinfectant dispenser, 1000 ml, suitable for standard disposable bottles, refillable containers and hygiene packages, matt silver anodised aluminium housing, short stainless steel operating lever, with identification clip, incl. empty bottle, dishwasher-safe, replaceable plastic pump, pump can be quickly and simply removed for cleaning through front removal - can be put back into service in reverse order with "push and click" system, autoclavable and dishwasher-safe dispenser Dimensions: W 94 x H 341 x D 170 mm</p>

# IMP E A - IMP T A

Soap-/disinfectant dispenser for disposable bottles as well as refillable containers and hygiene packages, aluminium housing, short operating lever, 500 ml or 1000 ml

**ingo-man® plus IMP E A/KSP**

**Art.-No. 1417550**

. . . Pcs. Soap-/disinfectant dispenser, 500 ml, suitable for standard disposable bottles, refillable containers and hygiene packages, matt silver anodised aluminium housing, short stainless steel operating lever, with identification clip, incl. empty bottle, replaceable plastic spray pump, autoclavable and dishwasher-safe dispenser, pump can be quickly and simply removed for cleaning through front removal - can be put back into service in reverse order with "push and click" system, retrofittable smart functionality  
Dimensions: W 82 x H 305 x D 169 mm

**ingo-man® plus IMP T A/KSP**

**Art.-No. 1417590**

. . . Pcs. Soap-/disinfectant dispenser, 1000 ml, suitable for standard disposable bottles, refillable containers and hygiene packages, matt silver anodised aluminium housing, short stainless steel operating lever, with identification clip, incl. empty bottle, replaceable plastic spray pump, autoclavable and dishwasher-safe dispenser, pump can be quickly and simply removed for cleaning through front removal - can be put back into service in reverse order with "push and click" system  
Dimensions: W 94 x H 341 x D 170 mm

Product:

**ingo-man® plus**

Manufacturer:

OPHARDT HYGIENE-TECHNIK GmbH + Co. KG