

KILOTECH



Electronic Bench and Platform Scale



- **Built for the job**
- **Accuracy assured**
- **Indispensible warehouse partner**



- **Durability for longevity**
 - ✓ Durable, thick stainless steel platter allows for heavy loads without bending
 - ✓ Rugged mild steel frame structure
 - ✓ Your warehouse “go to” scale
- **2 scales in one**
 - ✓ Dual range – always the right sensitivity no matter how light or heavy the load
- **Back support**
 - ✓ Ideal for weighing products in bags or items that require extra support
- **Post mounted indicator**
 - ✓ Makes it easy to see the screen
- **Control your Quality – decrease errors**
 - ✓ Visual and audio cues help avoid errors and speed up the counting and checkweighing process
- **Indicator viewable in bright lights and from various angles**
 - ✓ Ideal for both industrial and restaurant applications





Key Features:

- ✓ Three weighing modes: lb, kg, pcs
- ✓ Ideal for shipping, receiving, check weighing or counting
- ✓ 2 set points (HI/OK/LO) with audible and visual alerts
- ✓ Accumulation function
- ✓ Hi contrast LCD with auto backlight - visible in bright light and various angles
- ✓ Back rack
- ✓ 6 key keyboard
- ✓ Full capacity TARE
- ✓ Battery or adapter operated
- ✓ Durable platter
- ✓ Sturdy frame





Specifications

Model	CYCLONE 150	CYCLONE 300
Capacity	0-60kg x 20g / 60-150kg x 50g 0-150lb x 0.05lb / 150-300lb x 0.1lb	0-150kg x 50g / 150-300kg x 100g 0-300lb x 0.1lb / 300-600lb x 0.2lb
Units of Measure	kg, lb, pcs	
Keyboard	6 Keys	
Audible alarm	Touch sound for key entry, low battery and High/Low alarm	
Working temperature	0° C ~40° C 32° F ~104° F	
Over capacity	Display "OL" when exceeds the full scale capacity	
Tare	Full capacity, push button tare	
Auto Zero tracking	Yes	
Display	High contrast LCD with auto backlight	
Remote display	No	
Current consumption	0.6vA	
Digit/height	6 digits/ 26 mm (1.02")	
Check weighing function	HI/LO/OK annunciate & alert buzz	
Set points	Select up to 2 set points for high and low limit settings	
Counting function	Yes	
Accumulate Weighing	Yes	
RS232	No	
Scale dimensions (W x D x H)	400 x 500 x 800 mm (15.75 x 19.69 x 31.5")	450 x 600 x 960 mm (17.72 x 23.62 x 37.8")
Scale weight	13 kg	20 kg
Box dimensions	840 x 600 x 228.6 mm (33 x 24 x 9")	940 x 640 x 228.6 mm (37 x 25 x 9")
Box weight	15 kg	23 kg
Power Supply	AC/DC adapter & rechargeable battery	

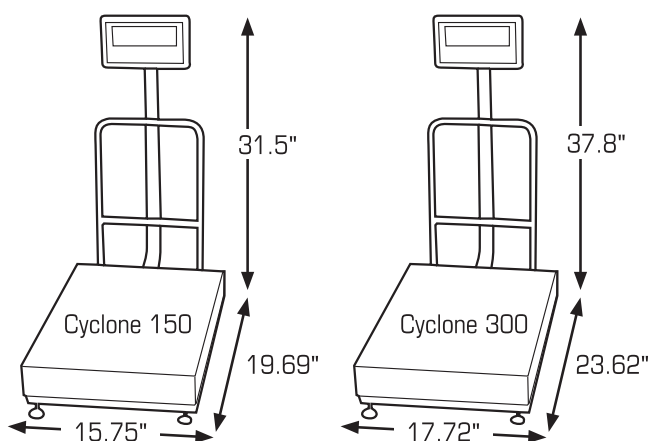

www.kilotech.com

KILOTECH
Accrédité par Mesures Canada

Specifications subject to change without prior notice
Spécifications sujettes à être améliorées sans préavis
MAR03232016