

WAVEBRAKE® DOWN-PRESS BUCKET AND WRINGER

With features that surpass traditional mop buckets, the new generation WaveBrake® helps to clean floors with less effort to get the job done safer, without sacrificing quality and durability.

Features and Benefits:

- Up to 80% less splashing.* Patented WaveBrake® baffles result in less splashing while mopping and maneuvering, helping to create a safer environment for patrons and staff
- WaveBrake® wringers are guaranteed to last 5 years or 200,000 cycles
- Integrated handles and sink ledge make it easy to lift and empty the mop bucket with less strain
- Pour spout helps prevent water from spilling on to floors while emptying dirty water
- Integrated wringer-guides ensure a secure connection to mop bucket, providing stability while wringing and maneuvering
- Non-marking casters will not scuff floors to keep them looking their best

*versus competitive 35Qt U.S. single compartment mop bucket and wringer, not including divider bucket and accessories.

Colors Available:

- Yellow, Brown, Blue, Red, Green

Material Composition:

- Bucket and wringer are made with structural web-molded plastic
- Wringer and bail handles are made with steel
- Back of bucket red handle is polypropylene

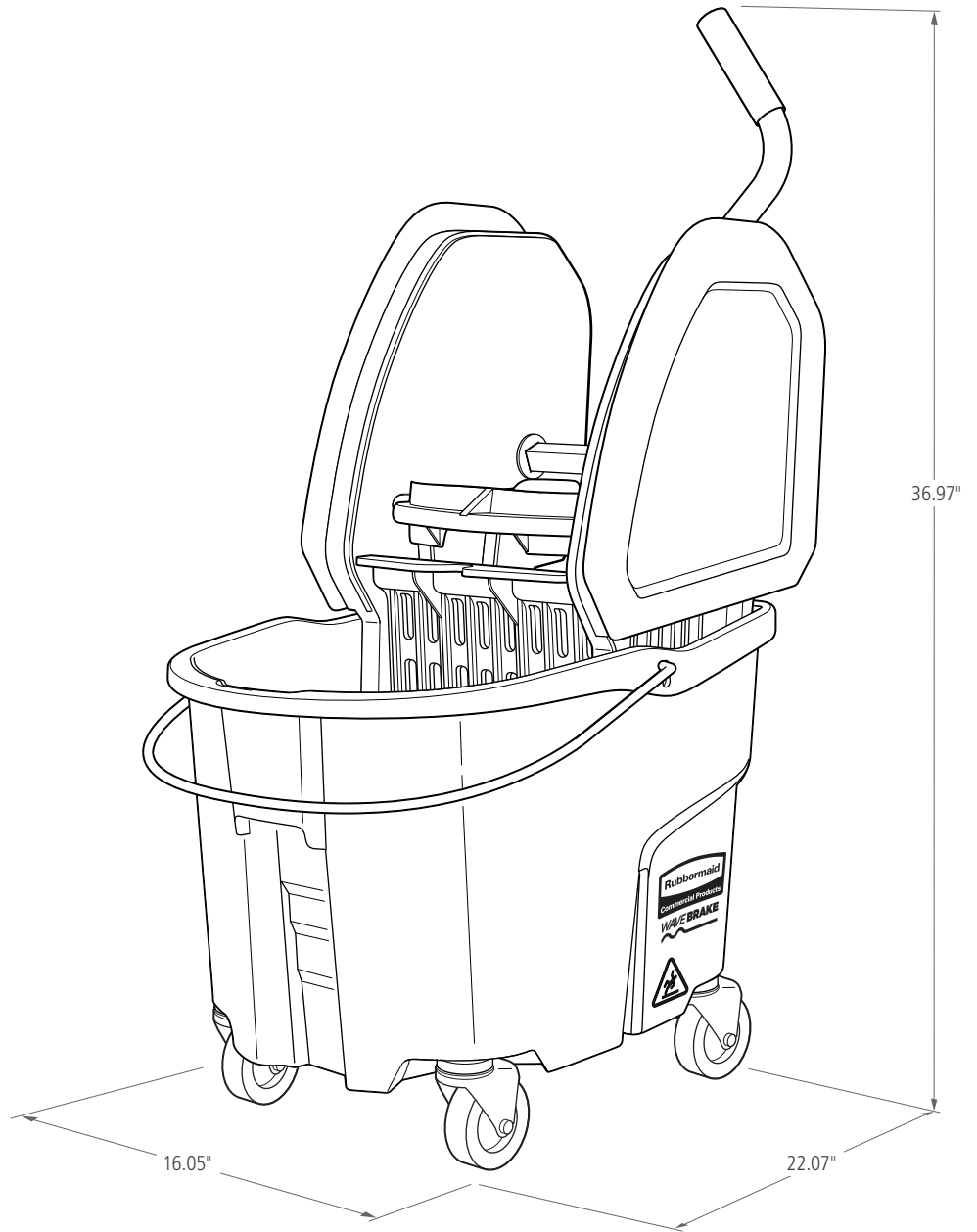

Unit Packaged Dimensions

SKU #	DESCRIPTION	COLOR	CAPACITY	LENGTH	WIDTH	HEIGHT	WEIGHT	CASE QTY
			QT	IN	IN	IN	LB	
FG757788YEL	35-QT WAVEBRAKE® DOWN-PRESS BUCKET AND WRINGER	YELLOW	35	22.07	16.05	36.97	19.15	1
FG757788BRN	35-QT WAVEBRAKE® DOWN-PRESS BUCKET AND WRINGER	BROWN	35	22.07	16.05	36.97	19.15	1
FG757888BLU	35-QT WAVEBRAKE® DOWN-PRESS BUCKET AND WRINGER	BLUE	35	22.07	16.05	36.97	19.15	1
FG757888RED	35-QT WAVEBRAKE® DOWN-PRESS BUCKET AND WRINGER	RED	35	22.07	16.05	36.97	19.15	1
FG757888GRN	35-QT WAVEBRAKE® DOWN-PRESS BUCKET AND WRINGER	GREEN	35	22.07	16.05	36.97	19.15	1

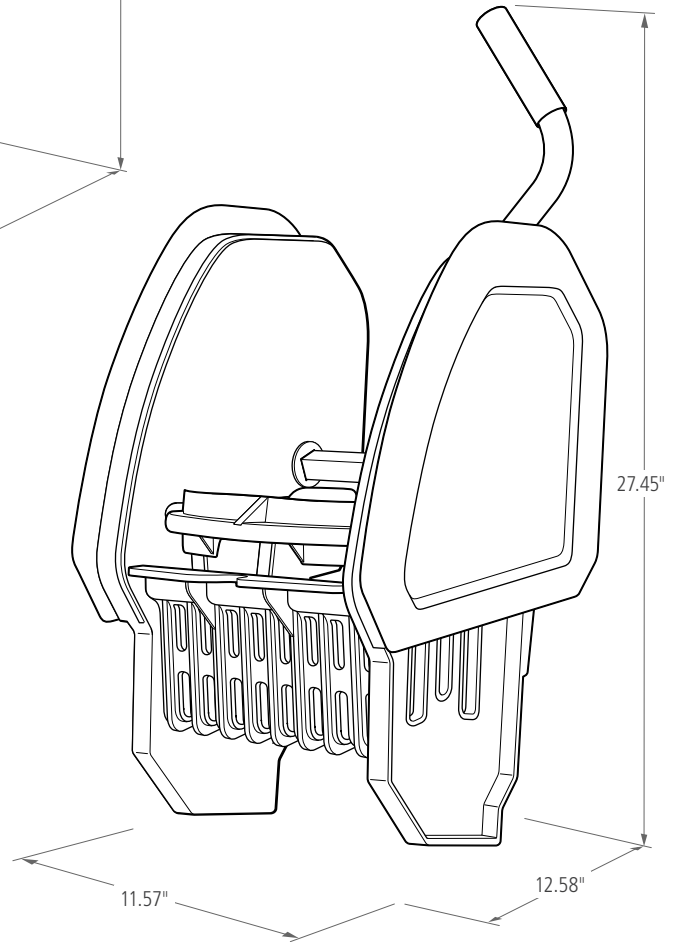
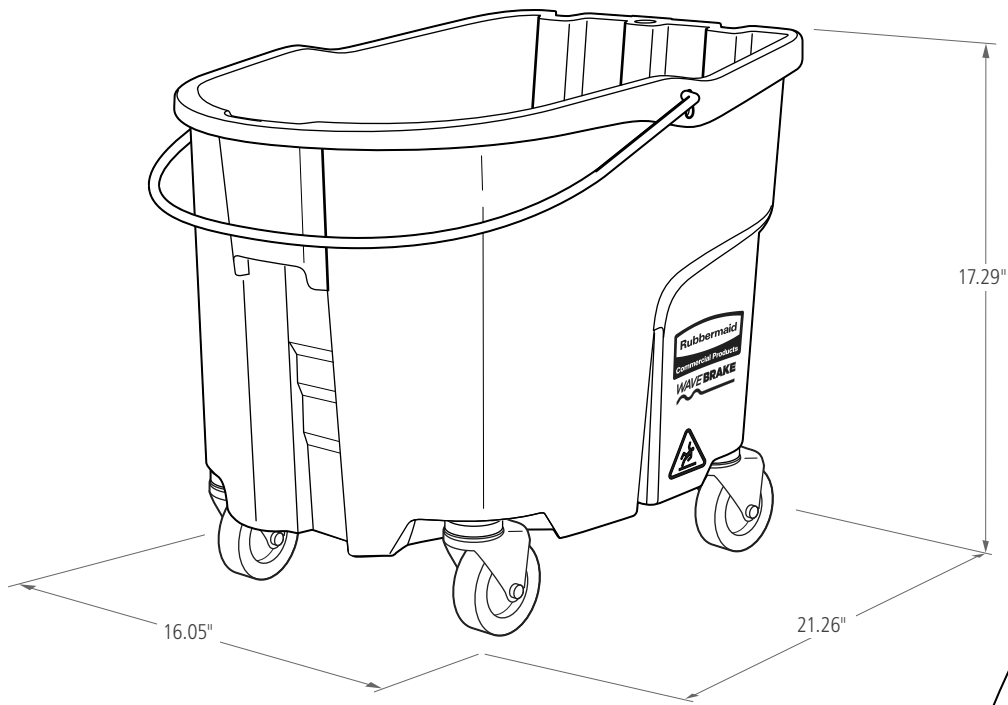

Replacement Parts

SKU #	DESCRIPTION	COLOR	CAPACITY	LENGTH	WIDTH	HEIGHT	WEIGHT	CASE QTY
				QT	IN	IN		
2064914	35-QT WAVEBRAKE® BUCKET AND CASTERS	YELLOW	35	21.26	16.05	17.29	9.65	4
2064906	35-QT WAVEBRAKE® BUCKET AND CASTERS	BROWN	35	21.26	16.05	17.29	9.65	4
2064904	35-QT WAVEBRAKE® BUCKET AND CASTERS	BLUE	35	21.26	16.05	17.29	9.65	4
2064910	35-QT WAVEBRAKE® BUCKET AND CASTERS	RED	35	21.26	16.05	17.29	9.65	4
2064916	35-QT WAVEBRAKE® BUCKET AND CASTERS	GREEN	35	21.26	16.05	17.29	9.65	4
2064959	WAVEBRAKE® DOWN-PRESS WRINGER	YELLOW	N/A	12.58	11.57	27.45	9.50	2
2065003	WAVEBRAKE® DOWN-PRESS WRINGER	BROWN	N/A	12.58	11.57	27.45	9.50	2
2064999	WAVEBRAKE® DOWN-PRESS WRINGER	BLUE	N/A	12.58	11.57	27.45	9.50	2
2065001	WAVEBRAKE® DOWN-PRESS WRINGER	RED	N/A	12.58	11.57	27.45	9.50	2
2064953	WAVEBRAKE® DOWN-PRESS WRINGER	GREEN	N/A	12.58	11.57	27.45	9.50	2

