

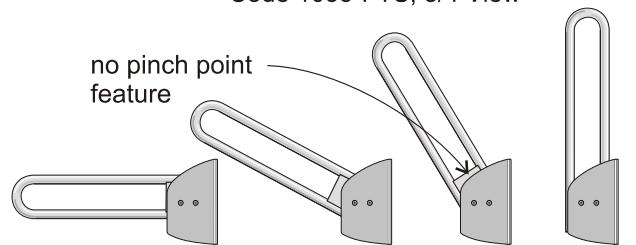

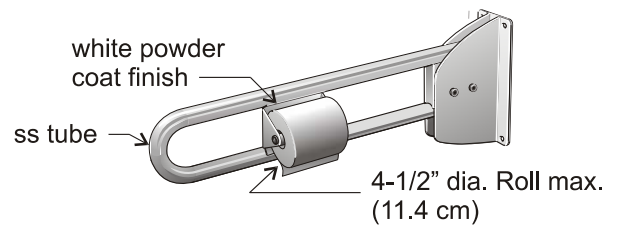

Flip up / Swing up Safety Rail

- Code 1055-W** Safety rail, all white finish
Code 1055-S Safety rail, stainless steel, (wall bracket in white finish)
Code 1055-FTS: Safety rail, stainless steel, with removable toilet paper dispenser in white finish.

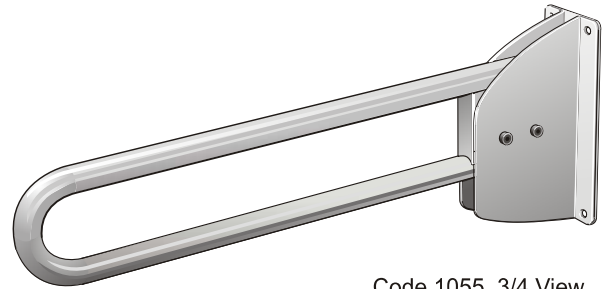
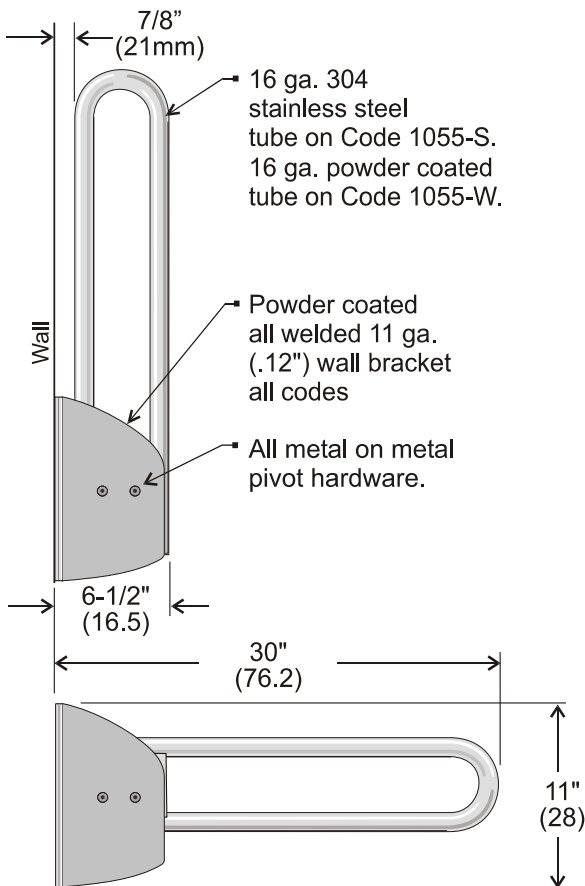

Side and retracted view

Specifications

- Site location:** • These units are highly recommended by barrier-free design experts because they provide the optimum approach path for wheelchair use. Consult applicable codes for specific requirements.
- Materials:** • Tubing is either 16 gauge type 304, 1-1/4" O.D. stainless steel, no. 4 finish or 16 gauge crs in white powder coat finish. Mandrel bending process on all curves maintains uniform bar diameter. Toilet tissue holder is fabricated from 18 ga. crs with white powder coat finish.
- Operation:** • Grab bar is manually lowered to horizontal support position and raised for departure. A locking system enables the flip up grab bar to be locked in either a horizontal or retracted position. Large inner web eliminates potential pinch point during operation.
- Installation:** • Secure to wall where adequate in wall backing exists. Use wall plate as a template to locate mounting holes. Drill holes and set anchors as appropriate. Mount grab bar and secure mounting screws. The 1055 flip up grab bar will sustain loads of 250 lbs. under it's intended use. Also the types of loads (especially dynamic) applied are hard to predict. It's up to the designer to determine the suitability of the use of these grab bars in this situation.
-  Caution: The swing up grab bar is only as strong as the anchors and wall to which it is attached and therefore it must be firmly secured and anchored to wall or approved carrier according to installation specifications in order to sustain the load(s) for which it is intended. We suggest installation by a qualified trades person.



Swing up Safety Rail

Code 1055 Mounting hole locations



Code 1055, 3/4 View

