

# K L I M B O

HELPS YOUR KIDS WASH THEIR HANDS



**KLIMBO-STAIR**, the removable and versatile step stool of the Klimbo product line, responds to children's need for independence by allowing them to easily reach the lavatories and hand dryers in public restrooms as well as other accessories that are difficult to reach because of their small size.

Affordable, mobile and light, Klimbo-Stair caters to the needs of young families and promotes healthy hygiene.

Klimbo-Stair can be conveniently stored under surfaces and easily moved as needed. Its wide, non-slip surfaces make it the ideal auxiliary step stool for commercial and institutional applications.

## PLACES WHERE KLIMBO IS IN DEMAND

- Institutional buildings
  - public libraries
  - multipurpose centres
  - schools
  - daycares
  - sports and recreational facilities
  - museums
  - citizen services
  - stadiums
- Shopping centres
- Movie theatres
- Rest stops and service stations
- Hospitals and clinics
- Hotels
- Amusement and aquatic parks, and zoos
- Restaurants
- Airports, train stations, terminals



**AFFORDABLE**



**STURDY  
AND SAFE**



**EASY TO  
MAINTAIN**

TECHNICAL SPECIFICATIONS

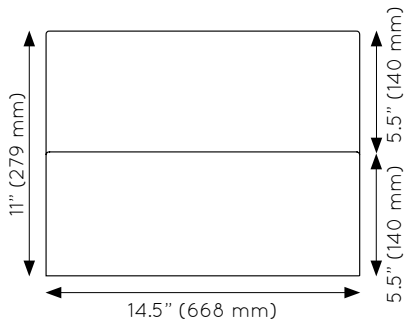

step stool front view

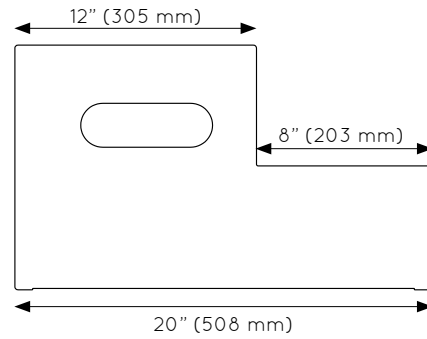

step stool side view

Materials	
Construction	1018 steel
Finish	Axalta polyester-based thermosetting powder coating and epoxy primer specifically formulated for use on steel surfaces
Non-slip surfaces	Non-slip rubber made from recycled materials
Decals	Clear PVC Logo, slogan and signs
Additional information	
Load capacity	410 kg (900 lb)
Warranty	Three years against manufacturing defects
Brand customization 	Klimbo can be customized to the clients' brand by special order and serve as a medium for conveying messages to their customers • Available in 190 <b>RAL classic</b> colours and in a wide range of metallic finishes from <b>Axalta Coating Systems</b>
CAD and Revit files	Available from Klimbo's website: <a href="http://www.klimbo.co/en-specification">www.klimbo.co/en-specification</a>
Product and packaging	
Unit weight	7.25 kg (16 lb)
Packaged unit weight	7.75 kg (17 lb)
Shipping box size	22" x 16" x 14" (560 mm x 406 mm x 356 mm)

**KLIMBO IS MANUFACTURED BY**

DLR inc.  
 P.O. Box 39026, Station Saint-Alexandre  
 Montreal (Qc) H3B 0B2 | Canada  
[www.klimbo.co](http://www.klimbo.co) | [www.facebook.com/KlimboStep](https://www.facebook.com/KlimboStep)  
[questions@klimbo.co](mailto:questions@klimbo.co)

**DEALER / DISTRIBUTOR**

