





Vortex Classic HS Hand Dryer

The unique futuristic design Energy Efficient & Hygienic High-speed Classic Hand Dryer with auto sensing and a rotating or fixed nozzle, ideal for retrofitting in Schools or Industries that require a rotating nozzle.

[Description](#) | [Short specs](#) | [Installation template](#) | [Warranty](#)

- **EXCLUSIVE 10 YEAR LIMITED WARRANTY**

- Outstanding inside out coverage
- Exclusive Diamond prolonged warranty

- **INCOMPARABLE TECHNOLOGY**

- Unique STERI-DRY germicidal bulb, eliminates 99.9% of bacteria & viruses
- Wi-Fi compatible
- Streamlined high efficiency low wattage motor
- Unique ceramic energy-conservation element

- **UNSURPASSED QUALITY**

- Built and produced in North America
- Meticulous, one-of-a-kind quality control procedures
- Built to last and function in the most challenging locations
- Complete die cast aluminum cover and wall plate
- High quality cast zinc 360° directional or lock nozzle

- **STATE OF THE ART DESIGN**

- Easily harmonized with any design washroom
- Classy, easy to clean surface
- Ideal for retrofitting existing, conventional high energy consuming hand dryers

- **MATCHLESS CUSTOMER SERVICE**

- Stand-by customer service attendants on line 24/7

- **UNEQUALLED DRYER ELEMENT**

- Our specially developed ceramic element eliminates all possible loss of heat with the tight-fit orifice element compartment

- **SUPREME DESIGNER COLOR PALETTE**

- Up-to-date in-stock designer color dryers with unequalised color options

Related Products





VORTEX Classic *STERI-DRY™* High Speed hand dryer

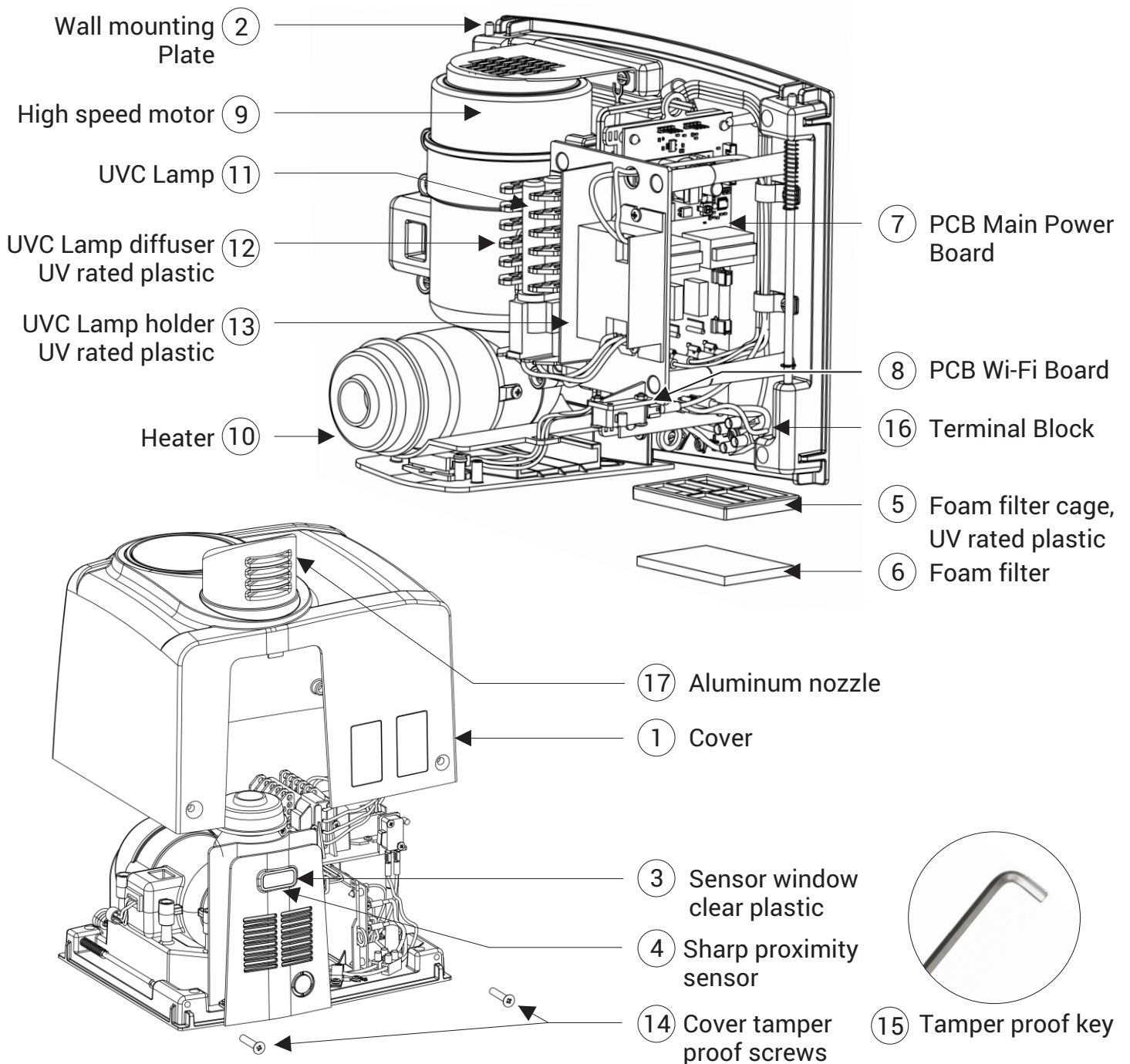

- 1.1.1.1 Mounting: surface-mounted.
- 1.1.1.2 Electrical Rating: (Classic HS) 1050 watts, 10 Amps, (110 - 120VAC, 50/60 Hz).
- 1.1.1.3 Electrical Rating: (Classic HS) 1050 watts, 5.2 Amps, (208-240VAC, 50/60 Hz).
- 1.1.1.4 Wi-Fi integrated technology can be monitored at distance for defaults such as motor and heater element failures.
- 1.1.1.5 Nozzle Type: single port multi directional for diffused, comfort dry.
- 1.1.1.6 Intake Air Filter: coarse foam type air filter to capture lint and debris from air.
- 1.1.1.7 Air Flow: 70 CFM at 246 mph (21648LFM).
- 1.1.1.8 *STERI-DRY™* germicidal technology UVC bulb.
- 1.1.1.9 Motor: through-flow discharge vacuum type with automatic reset 1.5 HP, 32,000 RPM.
- 1.1.1.10 Electronic Controls: automatic optical sensor. Operates while hands are under blower. Shut-off within 3 seconds when hands removed, or in 60 seconds if hands not removed.
- 1.1.1.11 Heater: nichrome wire element mounted inside ceramic housing with dual level safety protection - automatic resetting thermostat to open when air flow is restricted and close when air flow is resumed with back-up one use thermal cutoff. Heated air temperature is 111 degrees F (44 degrees C) at an ambient of 70 degrees F (21 degrees C).
- 1.1.1.12 Warranty: 10-year manufacturer limited warranty (not including replaceable filters or germicidal bulb).
- 1.1.1.13 Sound Level: 78 dBA at operator with hands; 68 dBA at 39.5 inches (1 meter), no hands.
- 1.1.1.14 Anti-microbial features inhibit the growth of bacteria, mold and fungus, extending the dryer's service life.
- 1.1.1.15 Cover Material: one piece, heavy duty, die-cast aluminum.
- 1.1.1.16 Weight 5.101kg (11 ¼ lbs) width 274.32mm (10.81") x height 236.60mm (9.315") x depth 253.22mm (9.97")

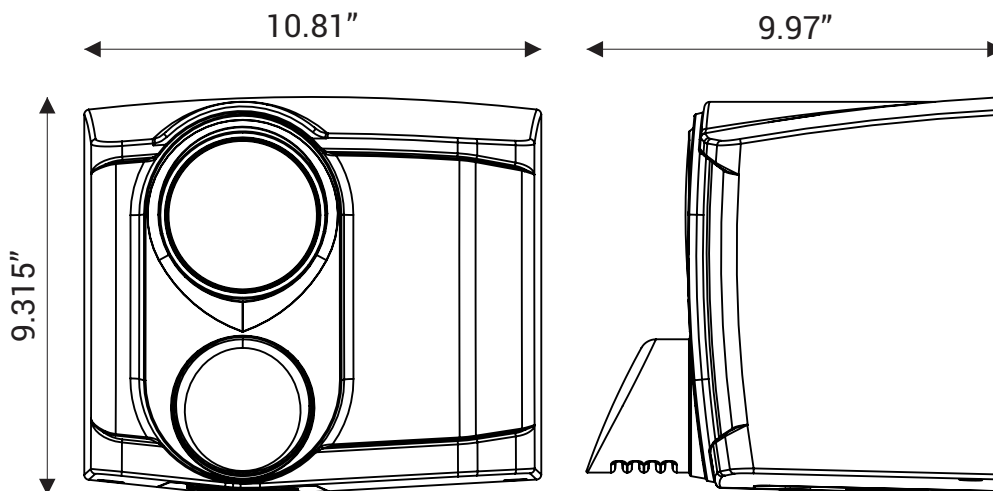

MODEL	COLOR	VOLTAGE	SKU
VCLH1BLK	BLACK	110-120VAC	769498991411
VCLH2BLK	BLACK	208-240VAC	769498991473
VCLH1WHT	WHITE	110-120VAC	769498991466
VCLH2WHT	WHITE	208-240VAC	769498991527
VCLH1CHA	CHARCOAL	110-120VAC	769498991428
VCLH2CHA	CHARCOAL	208-240VAC	769498991480
VCLH1CHR	CHROME	110-120VAC	769498991435
VCLH2CHR	CHROME	208-240VAC	769498991497
VCLH1RED	DARK RED	110-120VAC	769498991459
VCLH2RED	DARK RED	208-240VAC	769498991510
VCLH1CUS	CUSTOM	110-120VAC	769498991442
VCLH2CUS	CUSTOM	208-240VAC	769498991503



Vortex Industries Inc.

2501 Dollard Avenue | LaSalle, Qc. Canada H8N 1S2
 1-844-9VORTEX | WWW.VORTEXDRYERS.COM